

# 10" Power Miter Saw

(Model 36-070)



PART NO. 899880 (0012)  
Copyright © 2000 Delta Machinery



**ESPAÑOL: PÁGINA 21**

To learn more about DELTA MACHINERY  
visit our website at: [www.deltamachinery.com](http://www.deltamachinery.com).

**For Parts, Service, Warranty or other Assistance,**

**please call 1-800-223-7278 (In Canada call 1-800-463-3582).**

# SAFETY RULES

Woodworking can be dangerous if safe and proper operating procedures are not followed. As with all machinery, there are certain hazards involved with the operation of the product. Using the machine with respect and caution will considerably lessen the possibility of personal injury. However, if normal safety precautions are overlooked or ignored, personal injury to the operator may result. Safety equipment such as guards, push sticks, hold-downs, featherboards, goggles, dust masks and hearing protection can reduce your potential for injury. But even the best guard won't make up for poor judgment, carelessness or inattention. Always use common sense and exercise caution in the workshop. If a procedure feels dangerous, don't try it. Figure out an alternative procedure that feels safer. REMEMBER: Your personal safety is your responsibility.

This machine was designed for certain applications only. Delta Machinery strongly recommends that this machine not be modified and/or used for any application other than that for which it was designed. If you have any questions relative to a particular application, DO NOT use the machine until you have first contacted Delta to determine if it can or should be performed on the product.

## Technical Service Manager

Delta Machinery  
4825 Highway 45 North  
Jackson, TN 38305

(IN CANADA: 505 SOUTHGATE DRIVE, GUELPH, ONTARIO N1H 6M7)



## WARNING: FAILURE TO FOLLOW THESE RULES MAY RESULT IN SERIOUS PERSONAL INJURY

- 1. FOR YOUR OWN SAFETY, READ INSTRUCTION MANUAL BEFORE OPERATING THE TOOL.** Learn the tool's application and limitations as well as the specific hazards peculiar to it.
- 2. KEEP GUARDS IN PLACE** and in working order.
- 3. ALWAYS WEAR EYE PROTECTION.**
- 4. REMOVE ADJUSTING KEYS AND WRENCHES.** Form habit of checking to see that keys and adjusting wrenches are removed from tool before turning it "on".
- 5. KEEP WORK AREA CLEAN.** Cluttered areas and benches invite accidents.
- 6. DON'T USE IN DANGEROUS ENVIRONMENT.** Don't use power tools in damp or wet locations, or expose them to rain. Keep work area well-lighted.
- 7. KEEP CHILDREN AND VISITORS AWAY.** All children and visitors should be kept a safe distance from work area.
- 8. MAKE WORKSHOP CHILDPROOF** – with padlocks, master switches, or by removing starter keys.
- 9. DON'T FORCE TOOL.** It will do the job better and be safer at the rate for which it was designed.
- 10. USE RIGHT TOOL.** Don't force tool or attachment to do a job for which it was not designed.
- 11. WEAR PROPER APPAREL.** No loose clothing, gloves, neckties, rings, bracelets, or other jewelry to get caught in moving parts. Nonslip footwear is recommended. Wear protective hair covering to contain long hair.
- 12. ALWAYS USE SAFETY GLASSES.** Wear safety glasses. Everyday eyeglasses only have impact resistant lenses; they are not safety glasses. Also use face or dust mask if cutting operation is dusty. These safety glasses must conform to ANSI Z87.1 requirements. Note: Approved glasses have Z87 printed or stamped on them.
- 13. SECURE WORK.** Use clamps or a vise to hold work when practical. It's safer than using your hand and frees both hands to operate tool.
- 14. DON'T OVERREACH.** Keep proper footing and balance at all times.
- 15. MAINTAIN TOOLS IN TOP CONDITION.** Keep tools sharp and clean for best and safest performance. Follow instructions for lubricating and changing accessories.
- 16. DISCONNECT TOOLS** before servicing and when changing accessories such as blades, bits, cutters, etc.
- 17. USE RECOMMENDED ACCESSORIES.** The use of accessories and attachments not recommended by Delta may cause hazards or risk of injury to persons.
- 18. REDUCE THE RISK OF UNINTENTIONAL STARTING.** Make sure switch is in "OFF" position before plugging in power cord.
- 19. NEVER STAND ON TOOL.** Serious injury could occur if the tool is tipped or if the cutting tool is accidentally contacted.
- 20. CHECK DAMAGED PARTS.** Before further use of the tool, a guard or other part that is damaged should be carefully checked to ensure that it will operate properly and perform its intended function – check for alignment of moving parts, binding of moving parts, breakage of parts, mounting, and any other conditions that may affect its operation. A guard or other part that is damaged should be properly repaired or replaced.
- 21. DIRECTION OF FEED.** Feed work into a blade or cutter against the direction of rotation of the blade or cutter only.
- 22. NEVER LEAVE TOOL RUNNING UNATTENDED. TURN POWER OFF.** Don't leave tool until it comes to a complete stop.
- 23. DRUGS, ALCOHOL, MEDICATION.** Do not operate tool while under the influence of drugs, alcohol or any medication.
- 24. MAKE SURE TOOL IS DISCONNECTED FROM POWER SUPPLY** while motor is being mounted, connected or re-connected.
- 25. THE DUST GENERATED** by certain woods and wood products can be injurious to your health. Always operate machinery in well ventilated areas and provide for proper dust removal. Use wood dust collection systems whenever possible.
- 26. ⚠ WARNING: SOME DUST CREATED BY POWER SANDING, SAWING, GRINDING, DRILLING, AND OTHER CONSTRUCTION ACTIVITIES** contains chemicals known to cause cancer, birth defects or other reproductive harm. Some examples of these chemicals are:
  - lead from lead-based paints,
  - crystalline silica from bricks and cement and other masonry products, and
  - arsenic and chromium from chemically-treated lumber.Your risk from these exposures varies, depending on how often you do this type of work. To reduce your exposure to these chemicals: work in a well ventilated area, and work with approved safety equipment, such as those dust masks that are specially designed to filter out microscopic particles.

**SAVE THESE INSTRUCTIONS**

# ADDITIONAL SAFETY RULES FOR MITER SAWS

1. **USE ONLY CROSS-CUTTING SAW BLADES. WHEN USING CARBIDE-TIPPED BLADES, MAKE SURE THEY HAVE A NEGATIVE HOOK ANGLE. DO NOT USE BLADES WITH DEEP GULLETS AS THEY CAN DEFLECT AND CONTACT GUARD.**
2. **DO NOT OPERATE** the miter saw until it is completely assembled and installed according to the instructions.
3. **IF YOU ARE NOT** thoroughly familiar with the operation of compound miter saws, obtain advice from your supervisor, instructor or other qualified person.
4. **DO NOT** perform any operation freehand. Secure or clamp workpiece firmly against fence.
5. **KEEP HANDS OUT OF PATH** of saw blade. If the workpiece you are cutting would cause your hand to be within hazard zone of the saw blade, the workpiece should be clamped in place before making cut.
6. **BE SURE** blade is sharp, runs freely and is free of vibration.
7. **ALLOW** the motor to come up to full speed before starting cut.
8. **KEEP** motor air slots clean and free of chips.
9. **ALWAYS MAKE SURE** all clamp handles are tight before cutting, even if the table is positioned in one of the positive stops.
10. **BE SURE** blade and flanges are clean and that arbor screw is tightened securely.
11. **USE** only blade flanges specified for your saw.
12. **NEVER** use blades larger or smaller in diameter than ten inches.
13. **NEVER** apply lubricants to the blade when it is running.
14. **ALWAYS** check the blade for cracks or damage before operation. Replace cracked or damaged blade immediately.
15. **NEVER** use blades recommended for operation at less than 6000 RPM.
16. **DO NOT** operate the saw without guards in place.
17. **ALWAYS** keep the lower blade guard in place and operating properly.
18. **NEVER** reach around or behind saw blade.
19. **MAKE SURE** blade is not contacting workpiece before switch is turned on.
20. **NEVER** lock the switch in the "ON" position.
21. **AFTER COMPLETING CUT**, release power switch and wait for coasting blade to stop before returning saw to raised position.
22. **TURN OFF** tool and wait for saw blade to stop before moving workpiece or changing settings.
23. **DO NOT** remove jammed or cut-off pieces until blade has stopped.
24. **NEVER** cut ferrous metals or masonry.
25. **NEVER** recut small pieces.
26. **PROVIDE** adequate support to the sides of the saw table for long workpieces.
27. **NEVER** use the miter saw in an area with flammable liquids or gases.
28. **NEVER** use solvents to clean plastic parts. Solvents could possibly dissolve or otherwise damage the material. Only a soft damp cloth should be used to clean plastic parts.
29. **DISCONNECT** power before changing blades or servicing.
30. **DISCONNECT** saw from power source and clean the machine before leaving it.
31. **MAKE SURE** the work area is cleaned before leaving the machine.
32. **THE USE** of attachments and accessories not recommended by Delta may result in the risk of injuries.
33. **SHOULD** any part of your miter saw be missing, damaged or fail in any way, or any electrical component fail to perform properly, shut off switch and remove plug from power supply outlet. Replace missing, damaged or failed parts before resuming operation.
34. **ADDITIONAL INFORMATION** regarding the safe and proper operation of this product is available from the National Safety Council, 1121 Spring Lake Drive, Itasca, IL 60143-3201, in the Accident Prevention Manual for Industrial Operation and also in the Safety Data Sheets provided by the NSC. Please also refer to the American National Standard Institute ANSI O1.1 Safety Requirements for Woodworking Machinery and the U.S. Department of Labor OSHA 1910.213 Regulations.
35. **SAVE THESE INSTRUCTIONS.** Refer to them often and use them to instruct others.

# UNPACKING

1. Remove the miter saw and all loose items from the carton. **IMPORTANT: DO NOT LIFT THE MITER SAW BY THE SWITCH HANDLE AS THIS MAY CAUSE MISALIGNMENT. ALWAYS LIFT THE MACHINE BY THE BASE OR CARRYING HANDLE.** Fig. 2, illustrates the machine and all loose items after they have been removed from the carton.

- 1 - Miter Saw
- 2 - Wrenches for changing the blade
- 3 - Table lock handle

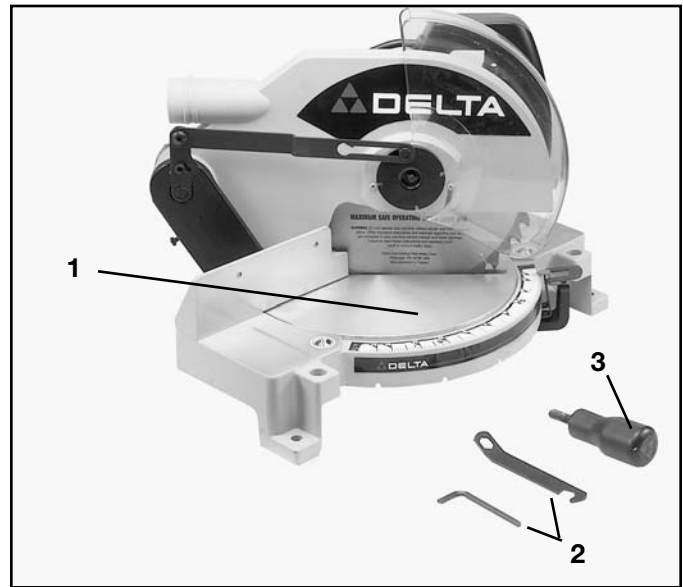

Fig. 2

## ASSEMBLY INSTRUCTIONS

**⚠ WARNING: FOR YOUR OWN SAFETY, DO NOT CONNECT THE MITER SAW TO THE POWER SOURCE UNTIL THE MACHINE IS COMPLETELY ASSEMBLED AND YOU HAVE READ AND UNDERSTOOD THE ENTIRE OWNERS MANUAL.**

### MOVING CUTTERHEAD TO THE UP POSITION

1. Push down on switch handle (A) Fig. 3, and pull out cuttinghead lockpin (B).

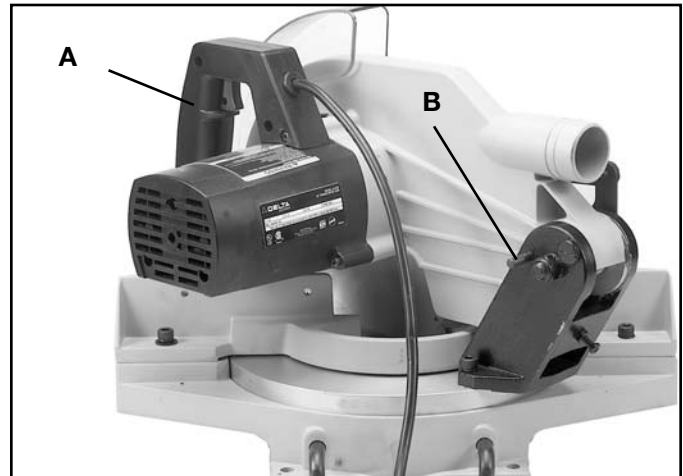

Fig. 3

2. The cuttinghead (C) can then be moved to the up position, as shown in Fig. 4.

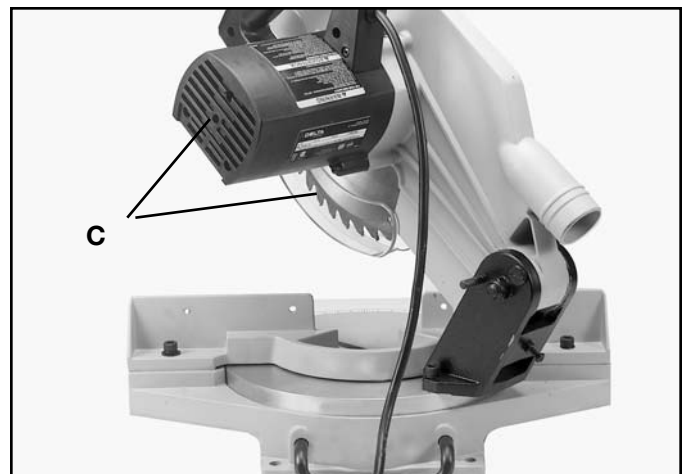

Fig. 4

## ASSEMBLING TABLE LOCK HANDLE

1. Thread table lock handle (A) Fig. 5, into the threaded hole (B) of the arm bracket.

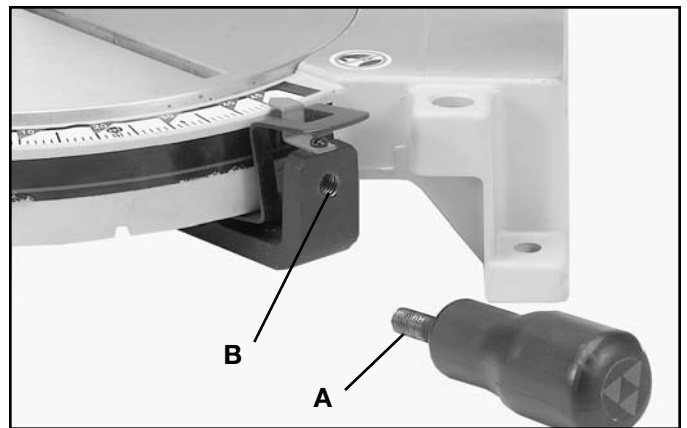

Fig. 5

## ROTATING TABLE TO 90 DEGREE POSITION

1. Loosen table lock handle (A) Fig. 6, one or two turns and depress index lever (B) to release 45 degree positive stop.
2. Rotate table to the left until index stop engages with the 90 degree positive stop (C) Fig. 6. Then tighten table lock handle (A).

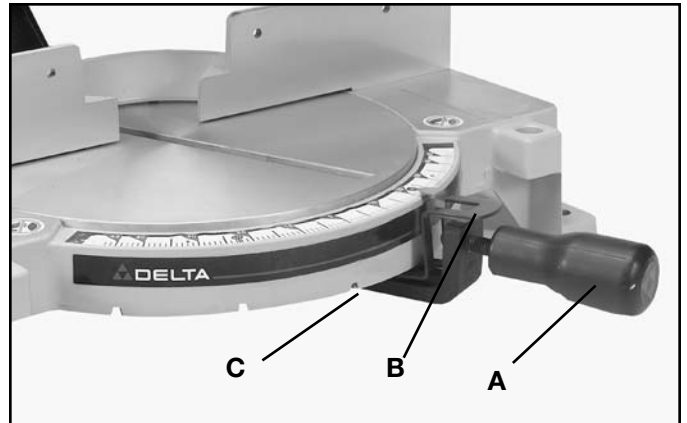

Fig. 6

## ASSEMBLING DUST BAG (OPTIONAL)

1. Assemble dust bag (A) Fig. 7, to the dust spout (B) making sure the wire ring (C) is engaged with the groove in the spout.

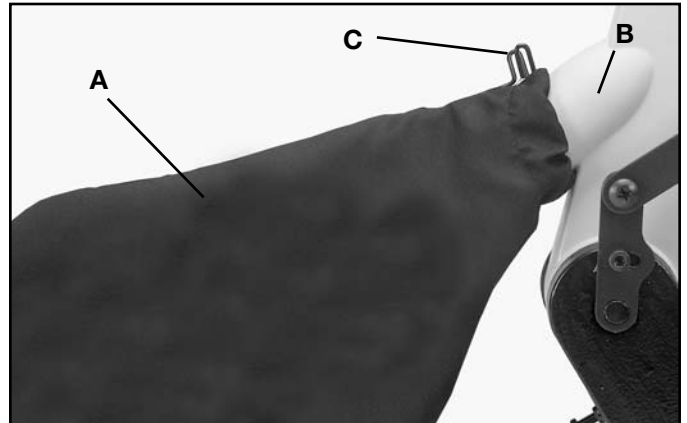

Fig. 7

## FASTENING MITER SAW TO SUPPORTING SURFACE

Before operating your compound miter saw, make sure it is firmly mounted to a sturdy workbench or other supporting surface. Four holes are provided, two of which are shown at (A) Fig. 8, for fastening the saw to a supporting surface.

When frequently moving the saw from place to place we suggest that the saw be mounted to a 3/4" piece of plywood. The saw can then be easily moved from place to place and the plywood clamped to the supporting surface using "C" clamps.

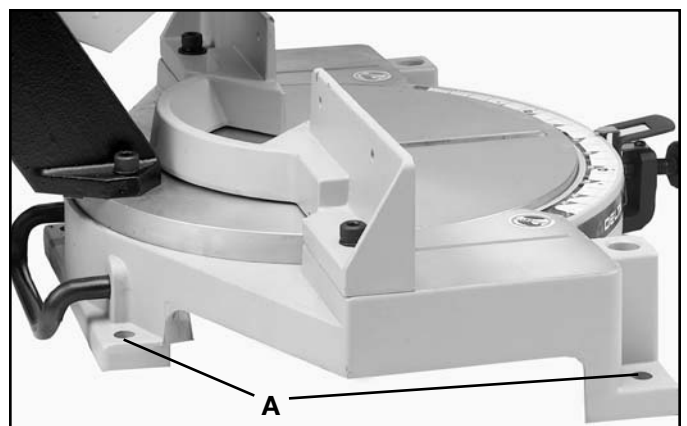

Fig. 8



# CONNECTING SAW TO POWER SOURCE

## POWER CONNECTIONS

A separate electrical circuit should be used for your tools. This circuit should not be less than #12 wire and should be protected with a 20 Amp time lag fuse. If an extension cord is used, use only 3-wire extension cords which have 3-prong grounding type plugs and 3-pole receptacles which accept the tool's plug. Before connecting the motor to the power line, make sure the switch is in the "OFF" position and be sure that the electric current is of the same characteristics as indicated on the tool. All line connections should make good contact. Running on low voltage will damage the motor.

## MOTOR SPECIFICATIONS

Your miter saw is wired for 110-120 volt, 60 HZ alternating current. Before connecting the miter saw to the power source, make sure the switch is in the "OFF" position. The motor provides a no-load speed of 5200 RPM.

## GROUNDING INSTRUCTIONS

 **WARNING: THIS TOOL MUST BE GROUNDED WHILE IN USE TO PROTECT THE OPERATOR FROM ELECTRIC SHOCK.**

1. All grounded, cord-connected tools: In the event of a malfunction or breakdown, grounding provides a path of least resistance for electric current to reduce the risk of electric shock. This tool is equipped with an electric cord having an equipment-grounding conductor and a grounding plug. The plug must be plugged into a matching outlet that is properly installed and grounded in accordance with all local codes and ordinances.

Do not modify the plug provided - if it will not fit the outlet, have the proper outlet installed by a qualified electrician.

Improper connection of the equipment-grounding conductor can result in risk of electric shock. The conductor with insulation having an outer surface that is green with or without yellow stripes is the equipment-grounding conductor. If repair or replacement of the electric cord or plug is necessary, do not connect the equipment grounding conductor to a live terminal.

Check with a qualified electrician or service personnel if the grounding instructions are not completely understood, or if in doubt as to whether the tool is properly grounded.

Use only 3-wire extension cords that have 3-prong grounding type plugs and 3-hole receptacles that accept the tool's plug, as shown in Fig. 9.

Repair or replace damaged or worn cord immediately.

2. Grounded, cord-connected tools intended for use on a supply circuit having a nominal rating less than 150 volts: This tool is intended for use on a normal 120-volt circuit and has a grounded plug that looks like the plug illustrated in Fig. 9.

If a properly grounded outlet is not available, a temporary adapter, shown in Fig. 10, may be used for connecting the 3-prong grounding type plug to a 2-prong receptacle. The temporary adapter should be used only until a properly grounded outlet can be installed by a qualified electrician. The green colored rigid ear, lug, or the like extending from the adapter must be connected to a permanent ground such as a properly grounded outlet box cover. Whenever the adapter is used, it must be held in place with a metal screw.

**NOTE: In Canada, the use of a temporary adapter is not permitted by the Canadian Electric Code.**

 **WARNING: IN ALL CASES, MAKE CERTAIN THE RECEPTACLE IN QUESTION IS PROPERLY GROUNDED. IF YOU ARE NOT SURE HAVE A CERTIFIED ELECTRICIAN CHECK THE RECEPTACLE.**

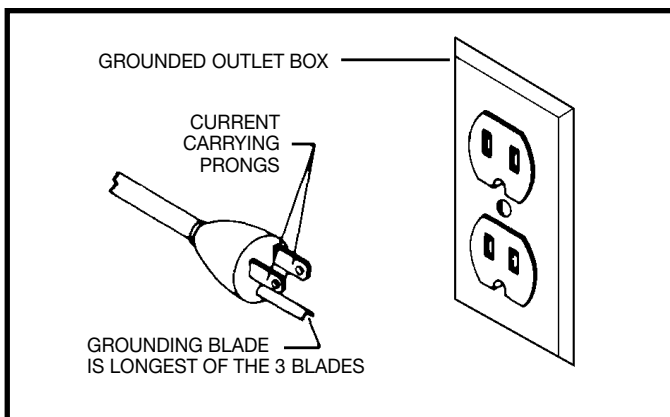

Fig. 9

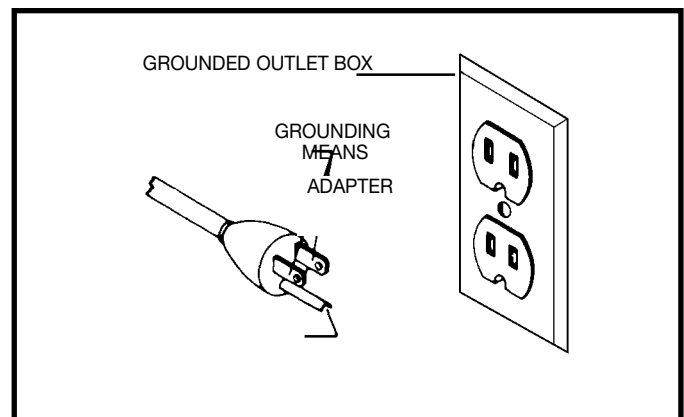

Fig. 10

# EXTENSION CORDS

Use proper extension cords. Make sure your extension cord is in good condition and is a 3-wire extension cord which has a 3-prong grounding type plug and a 3-pole receptacle which will accept the tool's plug. When using an extension cord, be sure to use one heavy enough to carry the current of the saw. An undersized cord will cause a drop in line voltage, resulting in loss of power and overheating. Fig. 11, shows the correct gauge to use depending on the cord length. If in doubt, use the next heavier gauge. The smaller the gauge number, the heavier the cord.

RECOMMENDED EXTENSION CORD SIZES FOR USE  
WITH STATIONARY ELECTRIC TOOLS

<b>MINIMUM GAUGE EXTENSION CORD</b>			
<b>Ampere Rating</b>	<b>Volts</b>	<b>Total Length of Cord in Feet</b>	<b>Gage of Extension Cord</b>
0-6	120	up to 25	18 AWG
0-6	120	25-50	16 AWG
0-6	120	50-100	16 AWG
0-6	120	100-150	14 AWG
6-10	120	up to 25	18 AWG
6-10	120	25-50	16 AWG
6-10	120	50-100	14 AWG
6-10	120	100-150	12 AWG
10-12	120	up to 25	16 AWG
10-12	120	25-50	16 AWG
10-12	120	50-100	14 AWG
10-12	120	100-150	12 AWG
12-16	120	up to 25	14 AWG
12-16	120	25-50	12 AWG
12-16	120	<b>GREATER THAN 50' NOT RECOMMENDED</b>	
0-6	240	up to 50	18 AWG
0-6	240	50-100	16 AWG
0-6	240	100-200	16 AWG
0-6	240	200-300	14 AWG
6-10	240	up to 50	18 AWG
6-10	240	50-100	16 AWG
6-10	240	100-200	14 AWG
6-10	240	200-300	12 AWG
10-12	240	up to 50	16 AWG
10-12	240	50-100	16 AWG
10-12	240	100-200	14 AWG
10-12	240	200-300	12 AWG
12-16	240	up to 50	14 AWG
12-16	240	50-100	12 AWG
12-16	240	<b>GREATER THAN 100' NOT RECOMMENDED</b>	

Fig. 11

# OPERATING INSTRUCTIONS

## FOREWORD

Delta Model 36-070 is a 10" Power Miter Saw designed to cut wood. Cross cutting and miter cutting are easy and accurate. It can crosscut up to 2-1/4" x 5-3/4", miter at 45 both left and right 2-1/4" x 4-1/8". It has positive miter stops at 0, 22.5, and 45 degrees both left and right, and is accurate to one half degree.

## STARTING AND STOPPING MACHINE

To start the machine, depress switch trigger (A) Fig. 12. To stop the machine, release the switch trigger.

This miter saw is equipped with an automatic electric blade brake. As soon as the switch trigger (A) Fig. 12, is released, the electric brake is activated and stops the blade in seconds.

**⚠ WARNING: A TURNING SAW BLADE CAN BE HAZARDOUS. AFTER COMPLETING CUT, RELEASE SWITCH TRIGGER (A) FIG. 12, TO ACTIVATE BLADE BRAKE. KEEP CUTTINGHEAD DOWN UNTIL BLADE HAS COME TO A COMPLETE STOP.**

**⚠ WARNING: THE TORQUE DEVELOPED DURING BRAKING MAY LOOSEN THE ARBOR SCREW. THE ARBOR SCREW SHOULD BE CHECKED PERIODICALLY AND TIGHTENED IF NECESSARY.**

## LOCKING SWITCH IN THE "OFF" POSITION

**IMPORTANT:** When the miter saw is not in use, the switch should be locked in the "OFF" position using a padlock (B) Fig. 13, (with 3/16" diameter shackle) through the two holes (A) Fig. 12 in the switch plate, as shown in (A) Fig. 12. NOTE: Padlock shown is available as accessory Model 50-325.

## ROTATING TABLE FOR MITER CUTTING

Your miter saw will cut any angle from a straight 90 degree cut to 47 degrees right and left. Simply loosen lock handle (A) Fig. 14, one or two turns, depress index lever (B) and move the control arm to the desired angle. THEN TIGHTEN LOCK HANDLE (A).

The miter saw is equipped with positive stops at the 0, 22-1/2 and 45 degree right and left positions. Simply loosen lock handle (A) Fig. 14, and move the control arm until the bottom of the index lever (B) engages into one of the positive stops, four of which are shown at (C). THEN TIGHTEN LOCK HANDLE (A). To disengage the positive stop, depress index lever (B).

**IMPORTANT: ALWAYS TIGHTEN LOCK HANDLE (A) FIG. 14, BEFORE CUTTING.**

## POINTER AND SCALE

A pointer (A) Fig. 15, is supplied which indicates the actual angle of cut. Each line on the scale (B) represents 1/2 degree. In effect, when the pointer is moved from one line to the next on the scale, the angle of cut is changed by 1/2 degree.

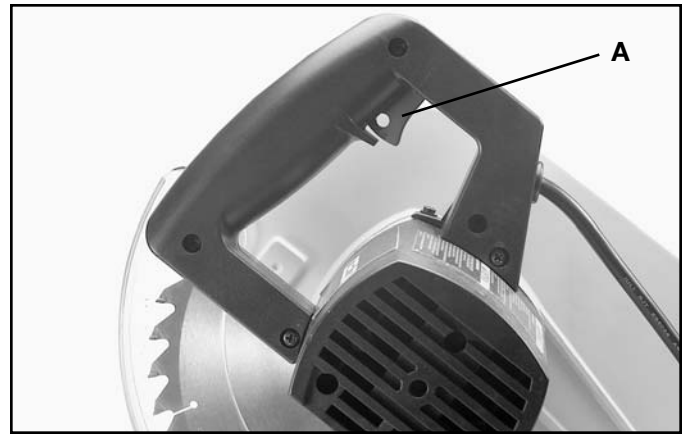

Fig. 12

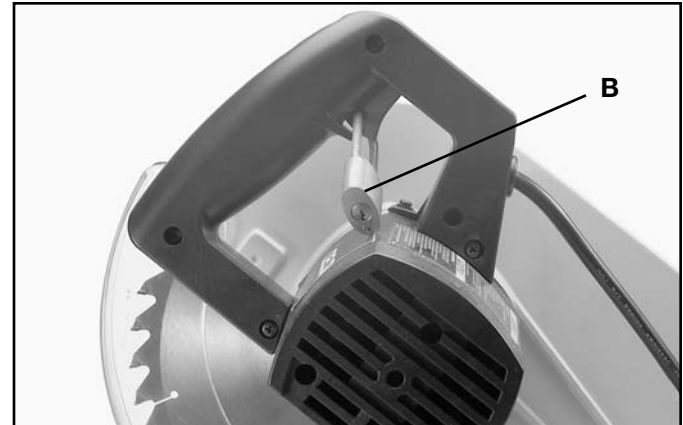

Fig. 13

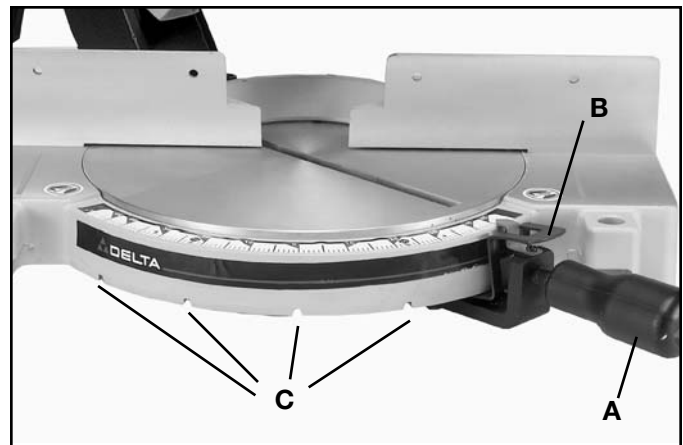

Fig. 14

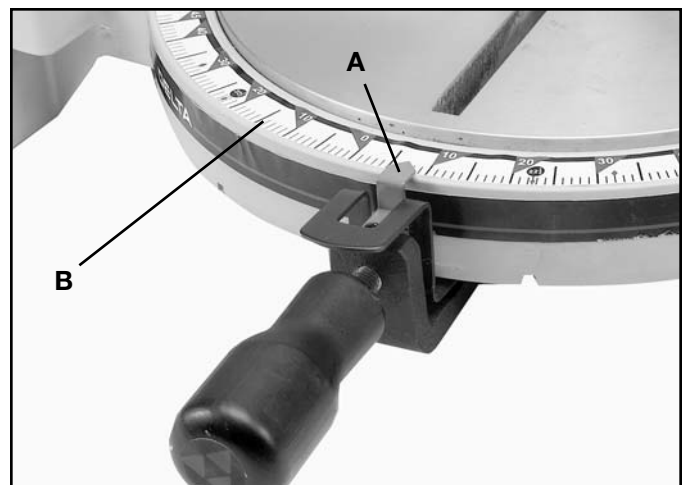

Fig. 15



## LOCKING CUTTINGHEAD IN THE DOWN POSITION

When transporting the miter saw, the cuttinghead should always be locked in the down position. This can be accomplished by lowering the cuttinghead (A) Fig. 16, and pushing pin (B) until other end of pin (B) engages with hole in cutting arm. **IMPORTANT: NEVER CARRY THE MITER SAW BY THE SWITCH HANDLE OR TABLE CONTROL HANDLE AS THIS MAY CAUSE MISALIGNMENT. ALWAYS LIFT THE MACHINE BY THE BASE OR CARRYING HANDLE.**



Fig. 16

## REAR SUPPORT/ CARRYING HANDLE

A rear support bar (A) Fig. 17, is provided to prevent the miter saw from tipping to the rear when the cuttinghead is returned to the up position after a cut has been made. For maximum support the bar (A) should be pulled out as far as possible.



Fig. 17

The support bar (A) also acts as a carrying handle, as shown in Fig. 18, when transporting the saw.



Fig. 18

## ADJUSTMENTS

### ADJUSTING DOWNWARD TRAVEL OF SAW BLADE

The downward travel of the saw blade can be limited to prevent the saw blade from contacting any metal surfaces of the machine.

Before adjusting downward travel, **DISCONNECT THE MACHINE FROM THE POWER SOURCE** and lower the blade as far as possible. Rotate the blade by hand to make certain the teeth do not contact any metal surfaces. This adjustment is made by loosening lock nut (A) Fig. 19, and turning the adjusting screw (B) in or out until the blade lowers to the desired position. Then tighten lock nut (A).

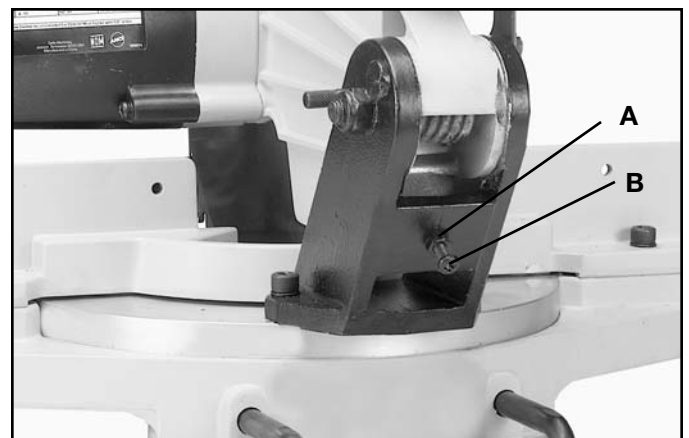

Fig. 19

## ADJUSTING BLADE PARALLEL TO TABLE OPENING

1. **DISCONNECT THE SAW FROM THE POWER SOURCE.**
2. Lower the cuttinghead and check to see if the saw blade (A) Fig. 20, is parallel to the left edge (B) of the table opening.
3. If an adjustment is necessary, loosen two screws, one of which is shown at (C) Fig. 20, and move the cuttinghead until the blade (A) is parallel with the left edge (B) of the table opening. Then tighten two screws (C).

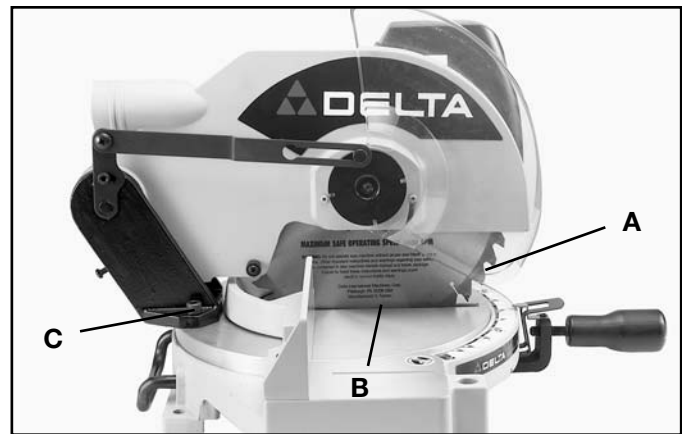

Fig. 20

## ADJUSTING FENCE 90 DEGREES TO BLADE

If the fence (A) Fig. 21, is ever removed from the saw it should be adjusted so it is 90 degrees to the blade when it is replaced, as follows:

1. **DISCONNECT THE SAW FROM THE POWER SOURCE.**
2. This adjustment should be made only after the blade has been adjusted parallel to table opening, as previously explained.
3. Using a square (B) Fig. 21, place one end of the square against the fence (A) and the other end against the slot in the table as shown.
4. If an adjustment is necessary, loosen the two screws (C) Fig. 22, and adjust fence 90 degrees to the table opening. Then tighten the two screws (C).

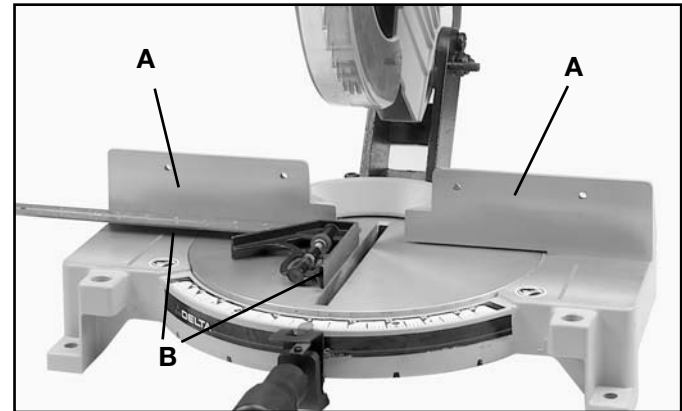

Fig. 21

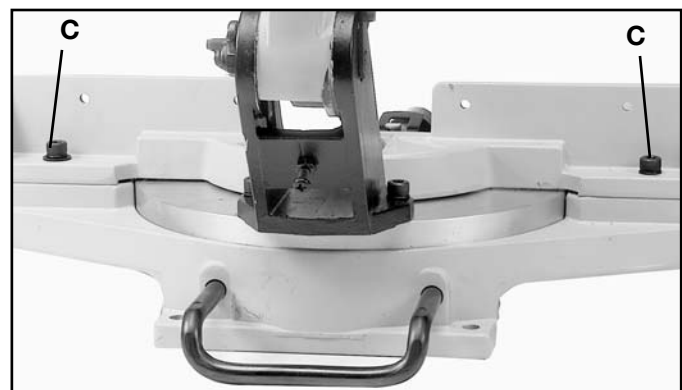

Fig. 22

## ADJUSTING POINTER

If it becomes necessary to adjust the pointer (A) Fig. 23, simply loosen screw (B), adjust the pointer accordingly and tighten screw (B).

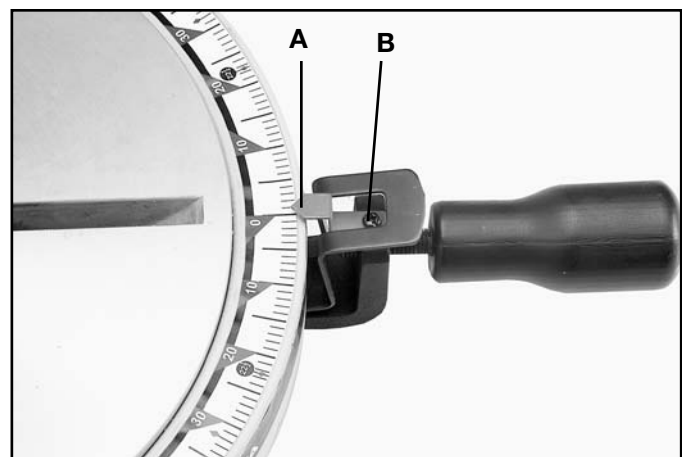

Fig. 23

# TYPICAL OPERATIONS AND HELPFUL HINTS

1. Before cutting, make certain the table is set at the correct angle and firmly locked in place.
2. Before cutting, determine that the workpiece is the right size for the saw.
3. Place the workpiece on the table and hold it firmly against the fence.
4. For best results cut at a slow, even cutting rate.
5. If the workpiece you are cutting causes your hand to be within 4 inches of the saw blade, the workpiece must be clamped to the fence before cutting.
6. Never attempt any freehand cutting (wood that is not held firmly against the fence and table).

## USING ACCESSORY 36-221 WORK CLAMP

1. An ideal accessory for use with your miter saw is the 36-221 Work Clamp, shown at (A) Fig. 24.

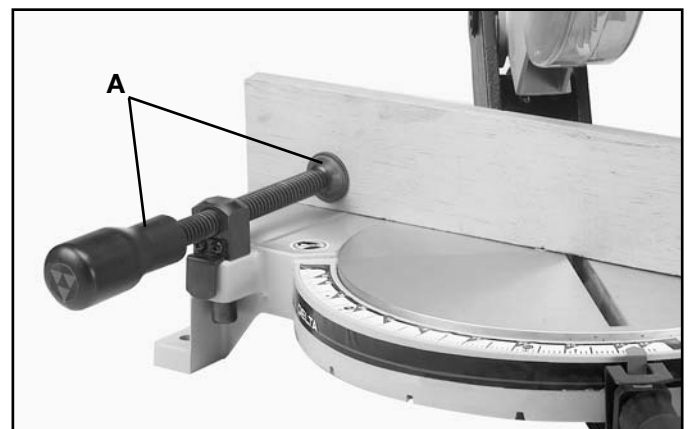

Fig. 24

2. Two holes (B) Fig. 25, are provided in the base of the miter saw enabling you to use the clamp (A) on either the right or left hand side of the saw blade.

**⚠ WARNING: Keep hands out of path of saw blade. If the workpiece you are cutting would cause your hand to be within 4 inches of the saw blade, the workpiece should be clamped in place before making cut.**

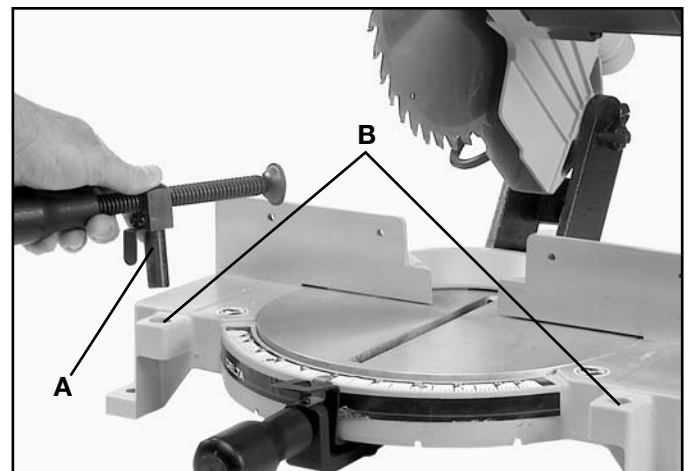

Fig. 25

# GENERAL CUTTING OPERATIONS

1. Your miter saw has the capacity to cut standard 2 x 4's laying flat or on edge, at the 45 degree right and left miter angles as shown in Figs. 26 and 27.



Fig. 26

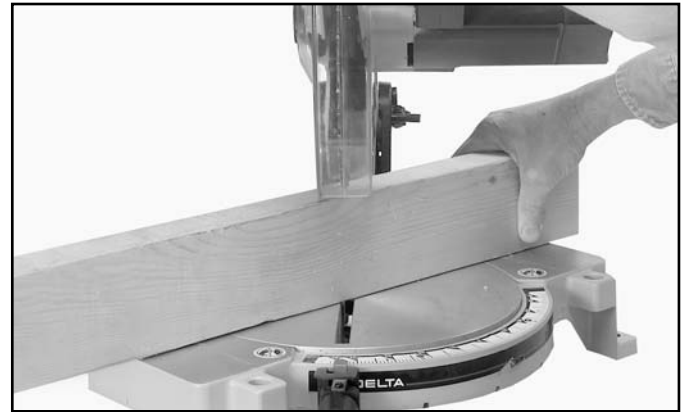

Fig. 27

2. A standard 2 x 6 can easily be cut in the 90 degree straight cut-off position in one pass, as shown in Fig. 28.



Fig. 28

3. Cutting a standard 4 x 4 is easily accomplished with your miter saw in one pass, as shown in Fig. 29.



Fig. 29

4. Cutting various sizes of plastic pipe is an easy job with the miter saw, as shown in Fig. 30.



Fig. 30

## CUTTING ALUMINUM

Aluminum extrusions such as used for making aluminum screens and storm windows can easily be cut with your miter saw. When cutting aluminum extrusions, or other sections that can be cut with a saw blade and are within the capacity of the machine, position the material so the blade is cutting through the smallest cross-section, as shown in Fig. 31. The wrong way to cut aluminum angles is illustrated in Fig. 32. Be sure to apply a stick wax (similar to Johnson's stick wax #140) to the blade before cutting any aluminum stock. This stick wax is available at most industrial mill supply houses. The stick wax provides proper lubrication and keeps chips from adhering to the blade. **NEVER APPLY A LUBRICANT TO THE BLADE WHILE THE MACHINE IS RUNNING.**

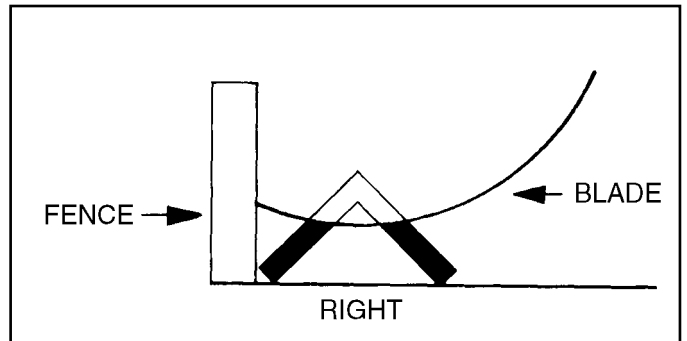

Fig. 31

## CUTTING BOWED MATERIAL

When cutting flat pieces, first check to see if the material is bowed. If it is, make sure the material is positioned on the table as shown in Fig. 33. If the material is positioned the wrong way, as shown in Fig. 34, the workpiece will pinch the blade near the completion of the cut.

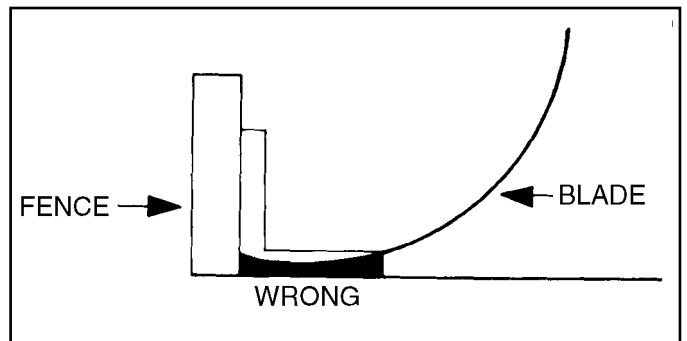

Fig. 32

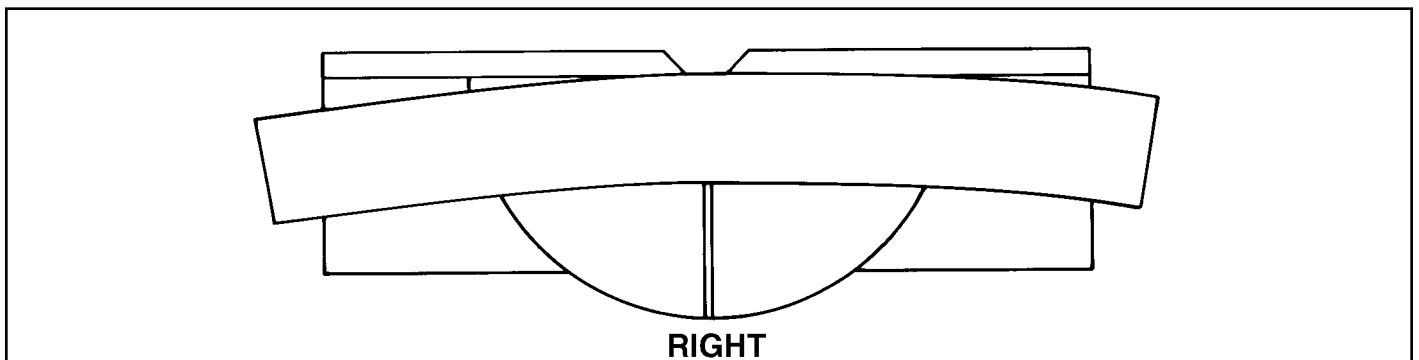

Fig. 33

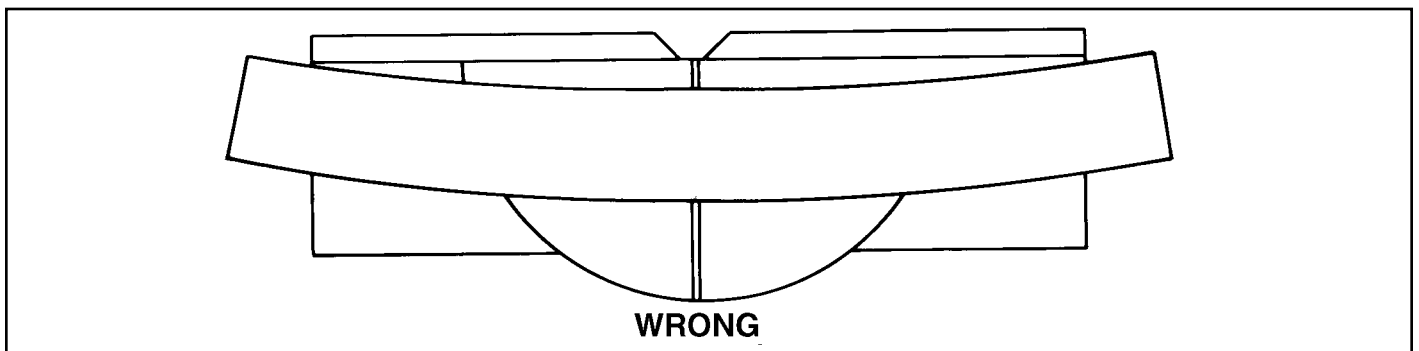

Fig. 34



# CUTTING CROWN MOULDINGS

1. There are several methods that can be used to cut crown mouldings on the miter saw. The method shown in Fig. 35, illustrates the contact surfaces (the surfaces that contact the wall and ceiling) of the crown moulding held firmly against the fence and table of the miter saw. This method is acceptable when making a small number of cuts but would not be practical for a production application as it may be difficult to firmly hold the work in this position. Also, this method means that the crown moulding must be positioned on the table in the upside down position.



Fig. 35

2. When a large number of repetitive cuts of crown moulding are required we suggest the use of filler blocks, as shown in Fig. 36 through Fig. 39. The majority of crown mouldings have contact surfaces at 52 and 38 degrees to the rear surface of the moulding and these angles must be utilized when jointing the face of the filler block. For crown mouldings with different angles, appropriate filler blocks can be produced.

3. Fig. 36 and Fig. 37, illustrate the filler block fastened to the miter saw fence with the face of the filler block extending outward from the top of the fence and down to the surface of the table. When the filler block is positioned in this manner, the crown moulding must be positioned on the table in the upside down position. This means that the surface of moulding that contacts the ceiling is against the table.

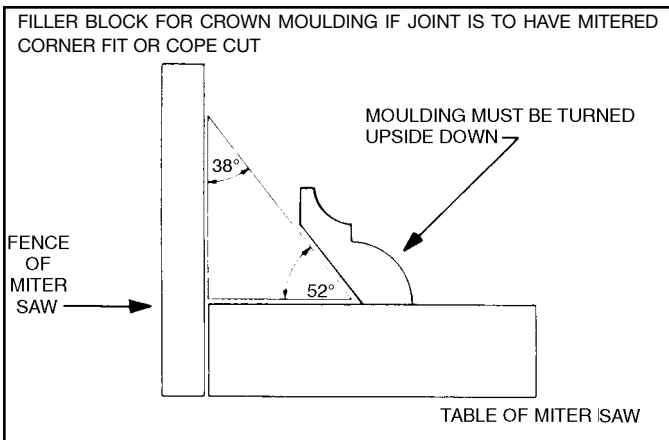

Fig. 36



Fig. 37

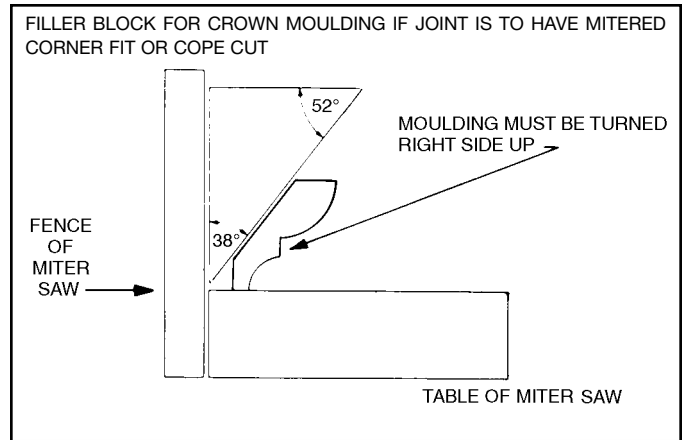

Fig. 38

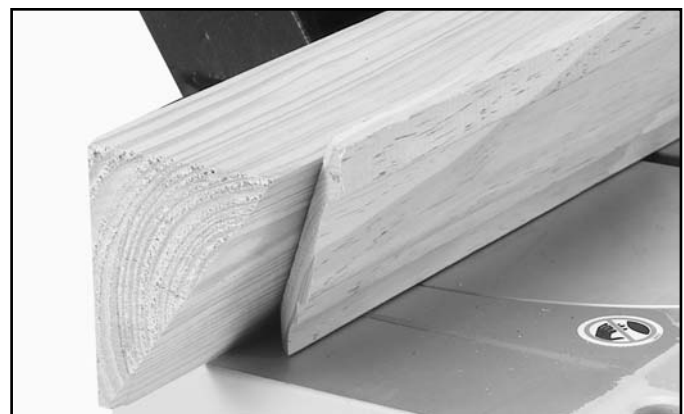

Fig. 39

5. Fasten the filler blocks to the fence using wood screws (A) through the two holes provided on each fence half, as shown in Fig. 40. This enables you to easily remove the filler blocks when not in use and quickly reassemble them to the fence when needed.

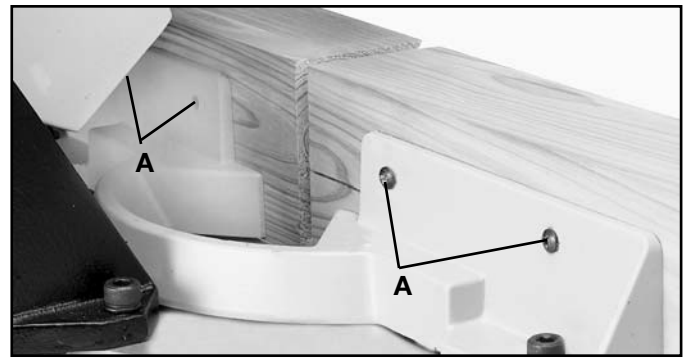

Fig. 40

6. Fig. 41, illustrates the miter saw arm in the 45 degree right miter position and the filler blocks fastened to the fence so that the moulding will be in the same position as it would be when nailed between the ceiling and wall.

When making this cut the moulding (B) on the left of the saw blade will be for an outside corner and the moulding (C) on the right of the saw blade will be for an inside corner.

To cut the mating pieces for mouldings (B) and (C) Fig. 41, simply rotate the miter saw arm to the 45 degree left miter position and make the cut, as shown in Fig. 42. In this case the moulding (D) on the left of the saw blade will be for an inside corner and the moulding (E) on the right of the saw blade will be for an outside corner.

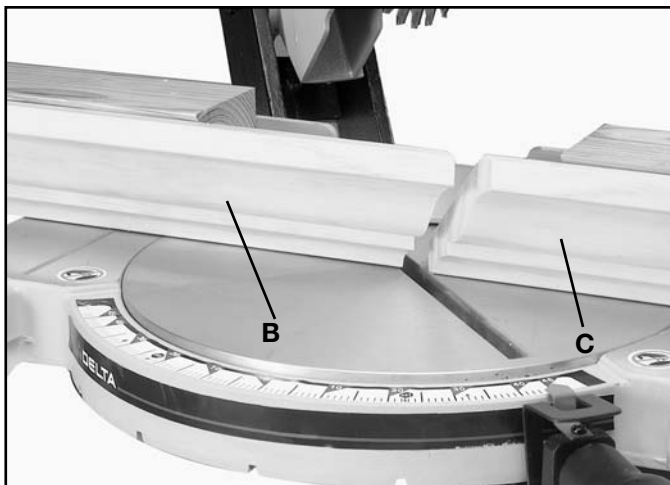

Fig. 41

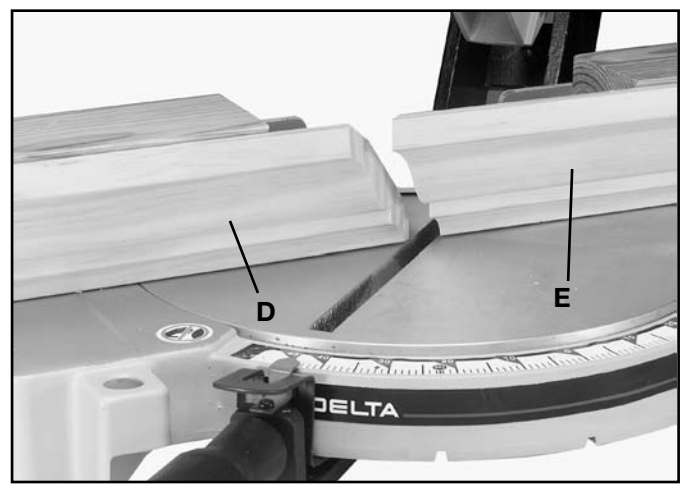

Fig. 42

# MAINTENANCE

## CHANGING THE BLADE

**⚠ WARNING: USE ONLY CROSS-CUTTING SAW BLADES. WHEN USING CARBIDE TIPPED BLADES, MAKE SURE THEY HAVE A NEGATIVE HOOK ANGLE. DO NOT USE BLADES WITH DEEP GULETS AS THEY CAN DEFLECT AND CONTACT THE GUARD. USE ONLY 10" DIAMETER SAW BLADES WHICH ARE RATED FOR 6000 RPM OR HIGHER AND HAVE 5/8" DIAMETER ARBOR HOLES.**

**1. DISCONNECT THE MACHINE FROM THE POWER SOURCE.**

2. Loosen screw (A) Fig. 43, and rotate cover (B) to the rear as shown in Fig. 44.

3. To remove the saw blade, insert hex wrench (C) Fig. 45, into the hex hole located on the rear end of the arbor shaft, to keep the shaft from turning.

4. Using wrench (D) Fig. 46, loosen arbor screw (E) by turning it clockwise

5. Remove arbor screw (E) Fig. 46, outside blade flange (F) and saw blade (G) from saw arbor.

6. Assemble new saw blade MAKING CERTAIN TEETH OF SAW BLADE ARE POINTING DOWN AT THE FRONT and re-assemble outside blade flange (F) Fig. 46, and arbor screw (E) by turning it counterclockwise using wrench (D) Fig. 46. At the same time use hex wrench (C) Fig. 45, to keep the arbor from turning.

7. Replace screw and cover that was rotated to the rear in STEP 2.

**⚠ WARNING: REMOVE WRENCHES (C) FIG. 45, AND (D) FIG. 46, BEFORE TURNING ON THE POWER.**

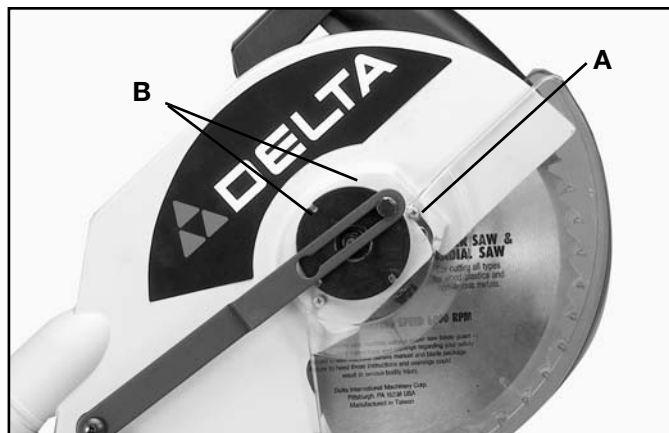

Fig. 43



Fig. 44



Fig. 45



Fig. 46

## BRUSH INSPECTION AND REPLACEMENT

**CAUTION: BEFORE INSPECTING THE BRUSHES, DISCONNECT THE MACHINE FROM THE POWER SOURCE.**

Brush life varies. It depends on the load on the motor. Check the brushes after the first 50 hours of use for a new machine or after a new set of brushes has been installed. After the first check, examine them after about 10 hours of use until such time that replacement is necessary. To inspect the brushes, proceed as follows:

1. Remove three screws (A) Fig. 47, and remove motor cover (B).

2. The brushes are located in the two holders (C) Fig. 48. Remove spade type terminal connector (D) and pull out brush holders (C).

3. Fig. 49, illustrates one of the brushes (E) removed from the holder (C). When the carbon on either brush (E) is worn to 3/16" in length or if either spring (F) or shunt wire is burned or damaged in any way, replace both brushes. If the brushes are found serviceable after removing, reinstall them in the same position as removed.

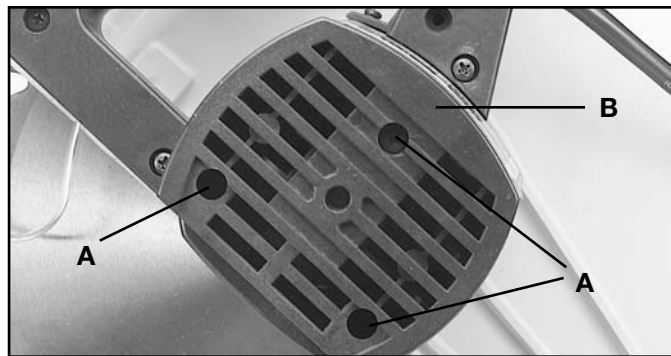

Fig. 47

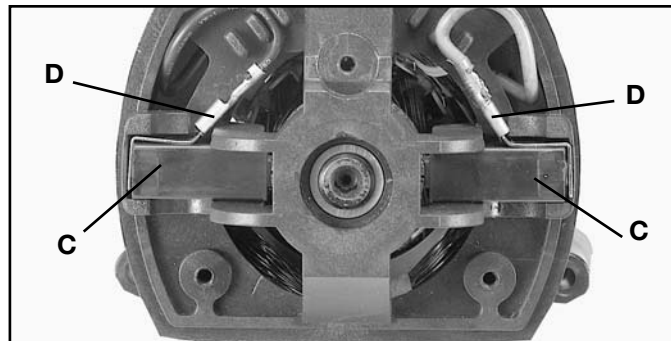

Fig. 48

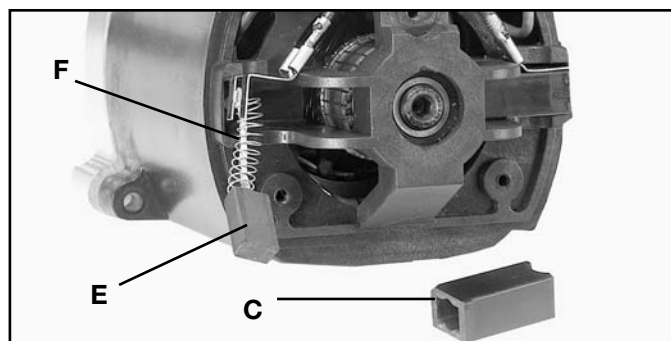

Fig. 49

## TABLE HAZARD AREA

**⚠ WARNING: THE AREA INSIDE THE TWO RED LINES (A) FIG. 50, ON THE TABLE IS DESIGNATED AS A HAZARD ZONE. NEVER PLACE YOUR HANDS INSIDE THIS AREA WHILE THE TOOL IS BEING OPERATED.**

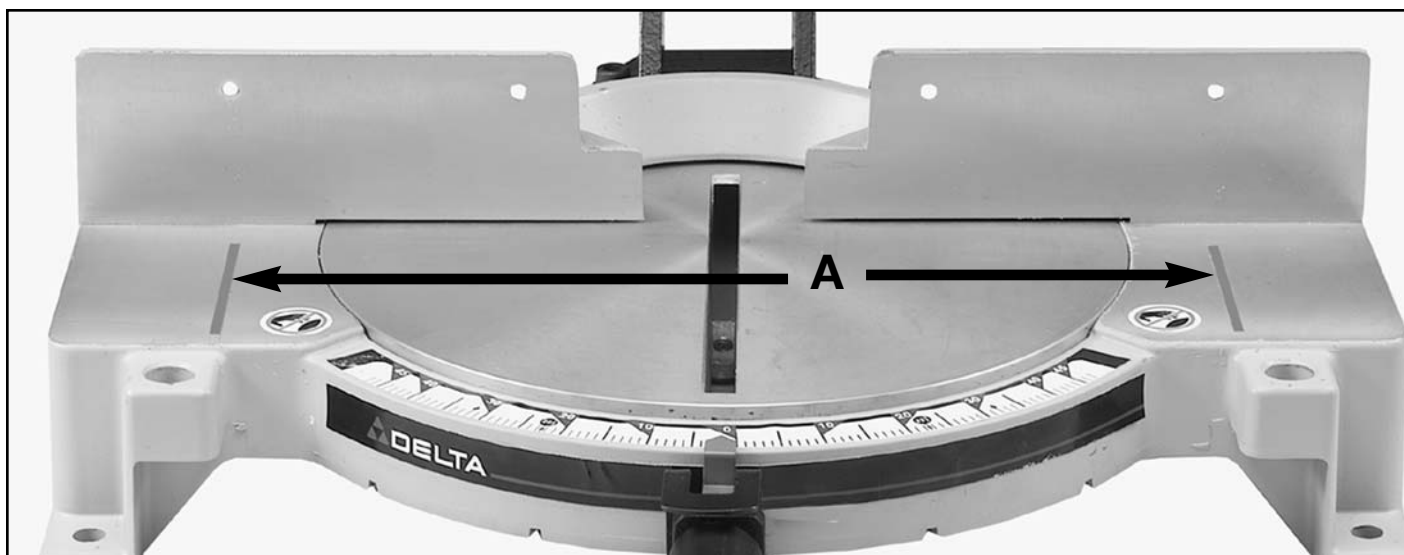

Fig. 50

# NOTES



# NOTES

# ACCESSORIES

A complete line of accessories are available from your Delta Supplier, Porter-Cable Delta Factory Service Centers, and Delta Authorized Service Stations. Please visit our Web Site [www.deltamachinery.com](http://www.deltamachinery.com) for a catalog or for the name of your nearest supplier.

**⚠ WARNING:** Since accessories, other than those offered by Delta, have not been tested with this product, use of such accessories could be hazardous. For safest operation, only Delta recommended accessories should be used with this product.

**36-221** Work Clamp

**36-222** Dust Bag



## PARTS, SERVICE OR WARRANTY ASSISTANCE

All Delta Machines and accessories are manufactured to high quality standards and are serviced by a network of Porter-Cable Delta Factory Service Centers and Delta Authorized Service Stations. To obtain additional information regarding your Delta quality product or to obtain parts, service, warranty assistance, or the location of the nearest service outlet, please call 1-800-223-7278 (In Canada call 1-800-463-3582).



### Delta Building Trades and Home Shop Machinery Two Year Limited Warranty

Delta will repair or replace, at its expense and at its option, any Delta machine, machine part, or machine accessory which in normal use has proven to be defective in workmanship or material, provided that the customer returns the product prepaid to a Delta factory service center or authorized service station with proof of purchase of the product within two years and provides Delta with reasonable opportunity to verify the alleged defect by inspection. Delta may require that electric motors be returned prepaid to a motor manufacturer's authorized station for inspection and repair or replacement. Delta will not be responsible for any asserted defect which has resulted from normal wear, misuse, abuse or repair or alteration made or specifically authorized by anyone other than an authorized Delta Service facility or representative. Under no circumstances will Delta be liable for incidental or consequential damages resulting from defective products. This warranty is Delta's sole warranty and sets forth the customer's exclusive remedy, with respect to defective products; all other warranties, express or implied, whether of merchantability, fitness for purpose, or otherwise, are expressly disclaimed by Delta.

Printed in U.S.A.

## PORTER-CABLE DELTA SERVICE CENTERS (CENTROS DE SERVICIO DE PORTER-CABLE DELTA)

Parts and Repair Service for Porter-Cable/Delta Power Tools are Available at These Locations  
(Obtenga Refaccion de Partes o Servicio para su Herramienta en los Siguientes Centros de Porter-Cable Delta)

### ARIZONA

Tempe 85282 (Phoenix)  
2400 West Southern Avenue  
Suite 105  
Phone: (602) 437-1200  
Fax: (602) 437-2200

### CALIFORNIA

Ontario 91761 (Los Angeles)  
3949A East Guasti Road  
Phone: (909) 390-5555  
Fax: (909) 390-5554

San Leandro 94577 (Oakland)  
3039 Teagarden Street  
Phone: (510) 357-9762  
Fax: (510) 357-7939

### COLORADO

Denver 80216  
5855 Stapleton Drive North  
Suite A-140  
Phone: (303) 370-6909  
Fax: (303) 370-6969

### FLORIDA

Davie 33314 (Miami)  
4343 South State Rd. 7 (441)  
Unit #107  
Phone: (954) 321-6635  
Fax: (954) 321-6638

Tampa 33609  
4538 W. Kennedy Boulevard  
Phone: (813) 877-9585  
Fax: (813) 289-7948

### GEORGIA

Forest Park 30297 (Atlanta)  
5442 Frontage Road,  
Suite 112  
Phone: (404) 608-0006  
Fax: (404) 608-1123

### ILLINOIS

Addison 60101 (Chicago)  
311 Laura Drive  
Phone: (630) 628-6100  
Fax: (630) 628-0023  
Woodridge 60517 (Chicago)  
2033 West 75th Street  
Phone: (630) 910-9200  
Fax: (630) 910-0360

### MARYLAND

Elkridge 21075 (Baltimore)  
7397-102 Washington Blvd.  
Phone: (410) 799-9394  
Fax: (410) 799-9398

### MASSACHUSETTS

Braintree 02185 (Boston)  
719 Granite Street  
Phone: (781) 848-9810  
Fax: (781) 848-6759

Franklin 02038 (Boston)  
Franklin Industrial Park  
101E Constitution Blvd.  
Phone: (508) 520-8802  
Fax: (508) 528-8089

### MICHIGAN

Madison Heights 48071 (Detroit)  
30475 Stephenson Highway  
Phone: (248) 597-5000  
Fax: (248) 597-5004

### MINNESOTA

Minneapolis 55429  
4315 68th Avenue North  
Phone: (612) 561-9080  
Fax: (612) 561-0653

### MISSOURI

North Kansas City 64116  
1141 Swift Avenue  
P.O. Box 12393  
Phone: (816) 221-2070  
Fax: (816) 221-2897

St. Louis 63119  
7574 Watson Road  
Phone: (314) 968-8950  
Fax: (314) 968-2790

### NEW YORK

Flushing 11365-1595 (N.Y.C.)  
175-25 Horace Harding Expwy.  
Phone: (718) 225-2040  
Fax: (718) 423-9619

### NORTH CAROLINA

Charlotte 28270  
9129 Monroe Road, Suite 115  
Phone: (704) 841-1176  
Fax: (704) 708-4625

### OHIO

Columbus 43214  
4560 Indianola Avenue  
Phone: (614) 263-0929  
Fax: (614) 263-1238

Cleveland 44125  
8001 Sweet Valley Drive  
Unit #19  
Phone: (216) 447-9030  
Fax: (216) 447-3097

### OREGON

Portland 97230  
4916 NE 122 nd Ave.  
Phone: (503) 252-0107  
Fax: (503) 252-2123

### PENNSYLVANIA

Willow Grove 19090  
520 North York Road  
Phone: (215) 658-1430  
Fax: (215) 658-1433

### TENNESSEE

Nashville 37214  
2262 Lebanon Pike  
Phone: (615) 882-0320  
Fax: (615) 882-0051

### TEXAS

Carrollton 75006 (Dallas)  
1300 Interstate 35 N, Suite 112  
Phone: (972) 446-2996  
Fax: (972) 446-8157

Houston 77055  
West 10 Business Center  
1008 Wirt Road, Suite 120  
Phone: (713) 682-0334  
Fax: (713) 682-4867

### WASHINGTON

Renton 98055 (Seattle)  
268 Southwest 43rd Street  
Phone: (425) 251-6680  
Fax: (425) 251-9337

Authorized Service Stations are located in many large cities. Telephone **800-487-8665** or **901-541-6042** for assistance locating one. Parts and accessories for Porter-Cable Delta products should be obtained by contacting any Porter-Cable Delta Distributor, Authorized Service Center, or Porter-Cable Delta Factory Service Center. If you do not have access to any of these, call **888-848-5175** and you will be directed to the nearest Porter-Cable Delta Factory Service Center. Las Estaciones de Servicio Autorizadas están ubicadas en muchas grandes ciudades. Llame al **800-487-8665** ó al **901-541-6042** para obtener asistencia a fin de localizar una. Las piezas y los accesorios para los productos Porter-Cable Delta deben obtenerse poniéndose en contacto con cualquier distribuidor Porter-Cable Delta, Centro de Servicio Autorizado o Centro de Servicio de Fábrica Porter-Cable Delta. Si no tiene acceso a ninguna de estas opciones, llame al **888-848-5175** y le dirigirán al Centro de Servicio de Fábrica Porter-Cable Delta más cercano.

## CANADIAN PORTER-CABLE DELTA SERVICE CENTERS

### ALBERTA

Bay 6, 2520-23rd St. N.E.  
Calgary, Alberta  
T2E 8L2  
Phone: (403) 735-6166  
Fax: (403) 735-6144

### BRITISH COLUMBIA

8520 Baxter Place  
Burnaby, B.C.  
V5A 4T8  
Phone: (604) 420-0102  
Fax: (604) 420-3522

### MANITOBA

1699 Dublin Avenue  
Winnipeg, Manitoba  
R3H 0H2  
Phone: (204) 633-9259  
Fax: (204) 632-1976

### ONTARIO

505 Southgate Drive  
Guelph, Ontario  
N1H 6M7  
Phone: (519) 836-2840  
Fax: (519) 767-4131

### QUÉBEC

1515 ave.  
St-Jean Baptiste,  
Québec, Québec  
G2E 5E2  
Phone: (418) 877-7112  
Fax: (418) 877-7123

1447, Begin  
St-Laurent, (Montréal),  
Québec  
H4R 1V8  
Phone: (514) 336-8772  
Fax: (514) 336-3505

The following are trademarks of PORTER-CABLE DELTA Corporation (Las siguientes son marcas registradas de PORTER-CABLE S.A.): BAMMER®, INNOVATION THAT WORKS®, JETSTREAM®, LASERLOC®, OMNIJIG®, POCKET CUTTER®, PORTA-BAND®, PORTA-PLANE®, PORTER-CABLE®, QUICKSAND®, SANDTRAP®, SAW BOSS®, SPEED-BLOC®, SPEEDMATIC®, SPEEDTRONIC®, STAIR-EASE®, THE PROFESSIONAL EDGE®, THE PROFESSIONAL SELECT®, TIGER CUB®, TIGER SAW®, TORQBUSTER®, WHISPER SERIES®, DURATRONIC™, FLEX™, FRAME SAW™, MICRO-SET™, MORTEN™, NETWORK™, RIPTIDE™, TRU-MATCH™, WOODWORKER'S CHOICE™.

Trademarks noted with ® are registered in the United States Patent and Trademark Office and may also be registered in other countries. Las Marcas Registradas con el signo de ® son registradas por la Oficina de Registros y Patentes de los Estados Unidos y también pueden estar registradas en otros países.