

1" Belt / 8" Disc Sander

(Model 31-340)

INSTRUCTION MANUAL



PART NO. 902120 (0112)
Copyright © 2001 Delta Machinery

 **DELTA**

To learn more about DELTA MACHINERY
visit our website at: www.deltamachinery.com.

For Parts, Service, Warranty or other Assistance,

please call **1-800-223-7278** (In Canada call **1-800-463-3582**).

ESPAÑOL: PÁGINA 19

GENERAL SAFETY RULES

Woodworking can be dangerous if safe and proper operating procedures are not followed. As with all machinery, there are certain hazards involved with the operation of the product. Using the machine with respect and caution will considerably lessen the possibility of personal injury. However, if normal safety precautions are overlooked or ignored, personal injury to the operator may result. Safety equipment such as guards, push sticks, hold-downs, featherboards, goggles, dust masks and hearing protection can reduce your potential for injury. But even the best guard won't make up for poor judgment, carelessness or inattention. Always use common sense and exercise caution in the workshop. If a procedure feels dangerous, don't try it. Figure out an alternative procedure that feels safer. **REMEMBER:** Your personal safety is your responsibility.

This machine was designed for certain applications only. Delta Machinery strongly recommends that this machine not be modified and/or used for any application other than that for which it was designed. If you have any questions relative to a particular application, **DO NOT** use the machine until you have first contacted Delta to determine if it can or should be performed on the product.

Technical Service Manager

Delta Machinery
4825 Highway 45 North
Jackson, TN 38305

(IN CANADA: 505 SOUTHGATE DRIVE, GUELPH, ONTARIO N1H 6M7)



WARNING: FAILURE TO FOLLOW THESE RULES MAY RESULT IN SERIOUS PERSONAL INJURY

1. **FOR YOUR OWN SAFETY, READ INSTRUCTION MANUAL BEFORE OPERATING THE TOOL.** Learn the tool's application and limitations as well as the specific hazards peculiar to it.

2. **KEEP GUARDS IN PLACE** and in working order.

3. **ALWAYS WEAR EYE PROTECTION.** Wear safety glasses. Everyday eyeglasses only have impact resistant lenses; they are not safety glasses. Also use face or dust mask if cutting operation is dusty. These safety glasses must conform to ANSI Z87.1 requirements. **NOTE:** Approved glasses have Z87 printed or stamped on them.

4. **REMOVE ADJUSTING KEYS AND WRENCHES.** Form habit of checking to see that keys and adjusting wrenches are removed from tool before turning it "on".

5. **KEEP WORK AREA CLEAN.** Cluttered areas and benches invite accidents.

6. **DON'T USE IN DANGEROUS ENVIRONMENT.** Don't use power tools in damp or wet locations, or expose them to rain. Keep work area well-lighted.

7. **KEEP CHILDREN AND VISITORS AWAY.** All children and visitors should be kept a safe distance from work area.

8. **MAKE WORKSHOP CHILDPROOF** – with padlocks, master switches, or by removing starter keys.

9. **DON'T FORCE TOOL.** It will do the job better and be safer at the rate for which it was designed.

10. **USE RIGHT TOOL.** Don't force tool or attachment to do a job for which it was not designed.

11. **WEAR PROPER APPAREL.** No loose clothing, gloves, neckties, rings, bracelets, or other jewelry to get caught in moving parts. Non-slip footwear is recommended. Wear protective hair covering to contain long hair.

12. **SECURE WORK.** Use clamps or a vise to hold work when practical. It's safer than using your hand and frees both hands to operate tool.

13. **DON'T OVERREACH.** Keep proper footing and balance at all times.

14. **MAINTAIN TOOLS IN TOP CONDITION.** Keep tools sharp and clean for best and safest performance. Follow instructions for lubricating and changing accessories.

15. **DISCONNECT TOOLS** before servicing and when changing accessories such as blades, bits, cutters, etc.

16. **USE RECOMMENDED ACCESSORIES.** The use of accessories and attachments not recommended by Delta may cause hazards or risk of injury to persons.

17. **REDUCE THE RISK OF UNINTENTIONAL STARTING.** Make sure switch is in "OFF" position before plugging in power cord. In the event of a power failure, move switch to the "OFF" position.

18. **NEVER STAND ON TOOL.** Serious injury could occur if the tool is tipped or if the cutting tool is accidentally contacted.

19. **CHECK DAMAGED PARTS.** Before further use of the tool, a guard or other part that is damaged should be carefully checked to ensure that it will operate properly and perform its intended function – check for alignment of moving parts, binding of moving parts, breakage of parts, mounting, and any other conditions that may affect its operation. A guard or other part that is damaged should be properly repaired or replaced.

20. **DIRECTION OF FEED.** Feed work into a blade or cutter against the direction of rotation of the blade or cutter only.

21. **NEVER LEAVE TOOL RUNNING UNATTENDED. TURN POWER OFF.** Don't leave tool until it comes to a complete stop.

22. **STAY ALERT, WATCH WHAT YOU ARE DOING, AND USE COMMON SENSE WHEN OPERATING A POWER TOOL. DO NOT USE TOOL WHILE TIRED OR UNDER THE INFLUENCE OF DRUGS, ALCOHOL, OR MEDICATION.** A moment of inattention while operating power tools may result in serious personal injury.

23. **MAKE SURE TOOL IS DISCONNECTED FROM POWER SUPPLY** while motor is being mounted, connected or reconnected.

24. **THE DUST GENERATED** by certain woods and wood products can be injurious to your health. Always operate machinery in well ventilated areas and provide for proper dust removal. Use wood dust collection systems whenever possible.

25.  **WARNING: SOME DUST CREATED BY POWER SANDING, SAWING, GRINDING, DRILLING, AND OTHER CONSTRUCTION ACTIVITIES** contains chemicals known to cause cancer, birth defects or other reproductive harm. Some examples of these chemicals are:

- lead from lead-based paints,
 - crystalline silica from bricks and cement and other masonry products, and
 - arsenic and chromium from chemically-treated lumber.
- Your risk from these exposures varies, depending on how often you do this type of work. To reduce your exposure to these chemicals: work in a well ventilated area, and work with approved safety equipment, such as those dust masks that are specially designed to filter out microscopic particles.

SAVE THESE INSTRUCTIONS.

Refer to them often and use them to instruct others.

ADDITIONAL SAFETY RULES FOR BELT / DISC SANDERS

 **WARNING: FAILURE TO FOLLOW THESE RULES MAY RESULT IN SERIOUS PERSONAL INJURY.**

1. **DO NOT OPERATE YOUR MACHINE UNTIL IT IS COMPLETELY ASSEMBLED AND INSTALLED ACCORDING TO THE INSTRUCTIONS.**
2. **THE DUST GENERATED BY CERTAIN WOODS AND WOOD PRODUCTS CAN BE INJURIOUS TO YOUR HEALTH. ALWAYS OPERATE MACHINERY IN WELL-VENTILATED AREAS AND PROVIDE FOR PROPER DUST REMOVAL. USE WOOD DUST COLLECTION SYSTEMS WHENEVER POSSIBLE.**
3. **THIS MACHINE CAN BE USED FOR PROCESSING WOOD AND METAL PRODUCTS; HOWEVER, COMBINING BOTH WOOD DUST AND METAL FILINGS CAN CREATE A FIRE HAZARD. MAKE CERTAIN THAT DUST COLLECTOR IS FREE OF WOOD DUST DEPOSITS BEFORE PROCESSING METAL PRODUCTS.**
4. **IF YOU ARE NOT** thoroughly familiar with the operation of Belt and Disc Sanders, obtain advice from your supervisor, instructor or other qualified person.
5. **IF THERE IS ANY TENDENCY** for the machine to tip over or move during certain operations such as when sanding long or heavy boards, the machine must be securely fastened to a supporting surface.
6. **MAKE SURE** sanding belt runs in the proper direction. Sanding belt must travel down at the front of the machine.
7. **MAKE SURE** the sanding belt is tracking correctly in order that it does not run off the pulleys.
8. **MAKE SURE** the sanding belt or disc is not torn or loose.
9. **HOLD** the work firmly when sanding.
10. **SUPPORT** workpiece firmly with the miter gage, back-stop or work table when sanding with the belt. **NOTE:** The only exception is curved work performed on the top wheel of belt.
11. **AVOID** kickback by sanding in accordance with directional arrows. Sand on downward side of disc. Sanding on the upward side could cause the workpiece to fly up causing injury.
12. **ALWAYS** maintain a maximum clearance of 1/16" or less between the table and the sanding belt or disc.
13. **NEVER** wear gloves or hold the work with a rag when sanding.
14. **SAND** with the grain of the work.
15. **DO NOT** sand pieces of material that are too small to be safely supported.
16. **AVOID** awkward hand positions where a sudden slip could cause a hand to move into the sanding belt or disc.
17. **WHEN** sanding a large workpiece, provide additional support at table height.
18. **NEVER** force the work. Slowing or stalling the motor will cause overheating.
19. **WHEN** sanding metal move the metal across the belt or disc and cool it when it becomes hot.
20. **WHEN** sanding metal never use a steady stream of water on the workpiece. Dip the workpiece in water to cool it.
21. **DO NOT** sand or polish magnesium. It could catch on fire.
22. **ALWAYS** remove scrap pieces and other objects from the belt and disc tables before turning the machine "ON."
23. **NEVER** perform layout, assembly or set-up work on the tables while the sander is operating.
24. **ALWAYS** turn the machine "OFF" and disconnect the cord from the power source before installing or removing accessories.
25. **NEVER** leave the machine work area when the power is "ON" or before the machine has come to a complete stop.
26. **ALWAYS** wear eye protection when operating the sander.
27. **THE USE** of attachments and accessories not recommended by Delta may result in the risk of injuries.
28. **SHOULD** any part of your sander be missing, damaged, or fail in any way, or any electrical components fail to perform properly, shut off switch and remove plug from power supply outlet. Replace missing, damaged or failed parts before resuming operation.
29. **ADDITIONAL INFORMATION** regarding the safe and proper operation of this product is available from the National Safety Council, 1121 Spring Lake Drive, Itasca, IL 60143-3201, in the Accident Prevention Manual for Industrial Operations and also in the Safety Data Sheets provided by the NSC. Please also refer to the American National Standards Institute ANSI 01.1 Safety Requirements for Woodworking Machinery and the U.S. Department of Labor OSHA 1910.213 Regulations.

**SAVE THESE INSTRUCTIONS.
Refer to them often
and use them to instruct others.**

POWER CONNECTIONS

A separate electrical circuit should be used for your machines. This circuit should not be less than #12 wire and should be protected with a 20 Amp time lag fuse. If an extension cord is used, use only 3-wire extension cords which have 3-prong grounding type plugs and matching receptacle which will accept the machine's plug. Before connecting the motor to the power line, make sure the switch is in the "OFF" position and be sure that the electric current is of the same characteristics as indicated on the machine. All line connections should make good contact. Running on low voltage will damage the motor.

 **WARNING: DO NOT EXPOSE THE MACHINE TO RAIN OR OPERATE THE MACHINE IN DAMP LOCATIONS.**

MOTOR SPECIFICATIONS

Your machine is wired for 120 volt, 60 HZ alternating current. Before connecting the machine to the power source, make sure the switch is in the "OFF" position.

GROUNDING INSTRUCTIONS

 **WARNING: THIS MACHINE MUST BE GROUNDED WHILE IN USE TO PROTECT THE OPERATOR FROM ELECTRIC SHOCK.**

1. All grounded, cord-connected machines:

In the event of a malfunction or breakdown, grounding provides a path of least resistance for electric current to reduce the risk of electric shock. This machine is equipped with an electric cord having an equipment-grounding conductor and a grounding plug. The plug must be plugged into a matching outlet that is properly installed and grounded in accordance with all local codes and ordinances.

Do not modify the plug provided - if it will not fit the outlet, have the proper outlet installed by a qualified electrician.

Improper connection of the equipment-grounding conductor can result in risk of electric shock. The conductor with insulation having an outer surface that is green with or without yellow stripes is the equipment-grounding conductor. If repair or replacement of the electric cord or plug is necessary, do not connect the equipment-grounding conductor to a live terminal.

Check with a qualified electrician or service personnel if the grounding instructions are not completely understood, or if in doubt as to whether the machine is properly grounded.

Use only 3-wire extension cords that have 3-prong grounding type plugs and matching 3-conductor receptacles that accept the machine's plug, as shown in Fig. A.

Repair or replace damaged or worn cord immediately.

2. Grounded, cord-connected machines intended for use on a supply circuit having a nominal rating less than 150 volts:

If the machine is intended for use on a circuit that has an outlet that looks like the one illustrated in Fig. A, the machine will have a grounding plug that looks like the plug illustrated in Fig. A. A temporary adapter, which looks like the adapter illustrated in Fig. B, may be used to connect this plug to a matching 2-conductor receptacle as shown in Fig. B if a properly grounded outlet is not available. The temporary adapter should be used only until a properly grounded outlet can be installed by a qualified electrician. The green-colored rigid ear, lug, and the like, extending from the adapter must be connected to a permanent ground such as a properly grounded outlet box. Whenever the adapter is used, it must be held in place with a metal screw.

NOTE: In Canada, the use of a temporary adapter is not permitted by the Canadian Electric Code.

 **WARNING: IN ALL CASES, MAKE CERTAIN THE RECEPTACLE IN QUESTION IS PROPERLY GROUNDED. IF YOU ARE NOT SURE HAVE A QUALIFIED ELECTRICIAN CHECK THE RECEPTACLE.**

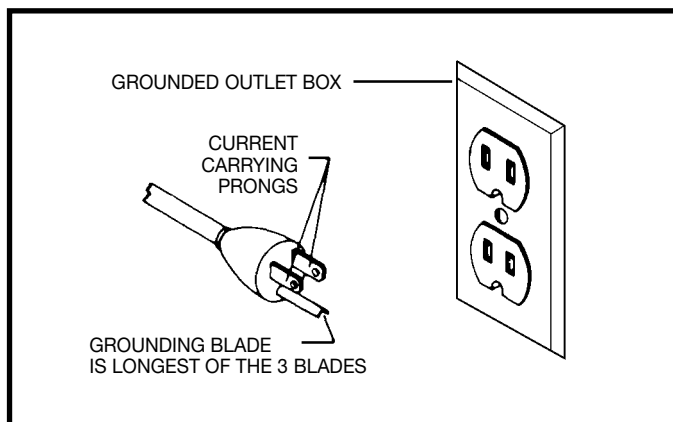

Fig. A

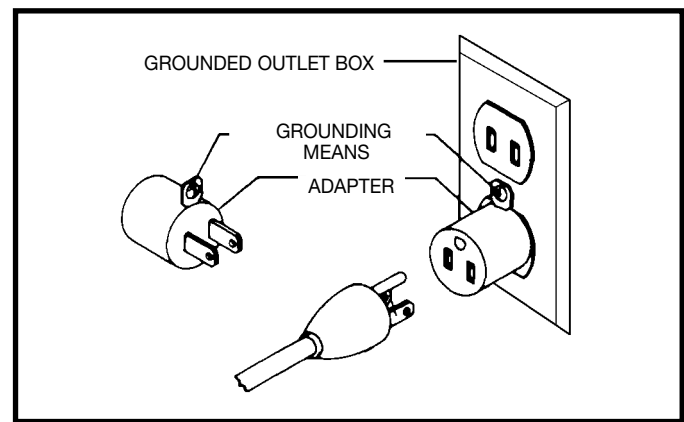

Fig. B

EXTENSION CORDS

Use proper extension cords. Make sure your extension cord is in good condition and is a 3-wire extension cord which has a 3-prong grounding type plug and matching receptacle which will accept the machine's plug. When using an extension cord, be sure to use one heavy enough to carry the current of the machine. An undersized cord will cause a drop in line voltage, resulting in loss of power and overheating. Fig. D, shows the correct gauge to use depending on the cord length. If in doubt, use the next heavier gauge. The smaller the gauge number, the heavier the cord.

MINIMUM GAUGE EXTENSION CORD			
RECOMMENDED SIZES FOR USE WITH STATIONARY ELECTRIC MACHINES			
Ampere Rating	Volts	Total Length of Cord in Feet	Gauge of Extension Cord
0-6	120	up to 25	18 AWG
		25-50	16 AWG
		50-100	16 AWG
		100-150	14 AWG
6-10	120	up to 25	18 AWG
		25-50	16 AWG
		50-100	14 AWG
		100-150	12 AWG
10-12	120	up to 25	16 AWG
		25-50	16 AWG
		50-100	14 AWG
		100-150	12 AWG
12-16	120	up to 25	14 AWG
		25-50	12 AWG
		GREATER THAN 50 FEET NOT RECOMMENDED	

Fig. D

OPERATING INSTRUCTIONS

FOREWORD

Delta Model 31-340 is the ultimate workshop machine for wood sanding and metal grinding. The 3000 SFM belt speed is ideal for metal grinding, deburring and sharpening, as well as sanding and buffing jobs. The 8" diameter disc operates at 1725 rpm for finishing hard and soft woods, plastics, compositions and more.

UNPACKING AND CLEANING

Carefully unpack the machine and all loose items from the shipping container(s). Remove the protective coating from all unpainted surfaces. This coating may be removed with a soft cloth moistened with kerosene (do not use acetone, gasoline or lacquer thinner for this purpose). After cleaning, cover the unpainted surfaces with a good quality household floor paste wax.

NOTICE: THE MANUAL COVER PHOTO ILLUSTRATES THE CURRENT PRODUCTION MODEL. ALL OTHER ILLUSTRATIONS ARE REPRESENTATIVE ONLY AND MAY NOT DEPICT THE ACTUAL COLOR, LABELING OR ACCESSORIES.

ASSEMBLY

⚠ WARNING: FOR YOUR OWN SAFETY, DO NOT CONNECT THE MACHINE TO THE POWER SOURCE UNTIL THE MACHINE IS COMPLETELY ASSEMBLED AND YOU READ AND UNDERSTAND THE ENTIRE INSTRUCTION MANUAL.

ASSEMBLING BELT UNIT TO BASE

1. Place a 10mm lockwasher (D) Fig. 1, and a 10mm flat washer (E) onto a M10x20mm hex socket head screw (A) and insert the screw up through the hole (B) in the base. Thread the screw into the tapped hole (C) in the bottom of the belt unit, repeat this process for the remaining hole. Do not completely tighten the two screws (A) Fig. 2 at this time.

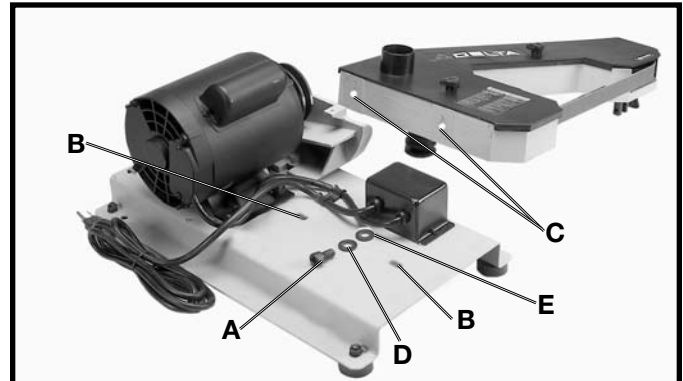

Fig. 1

2. Fig. 2, illustrates the two screws (A), inserted into the two holes in the bottom of the base.

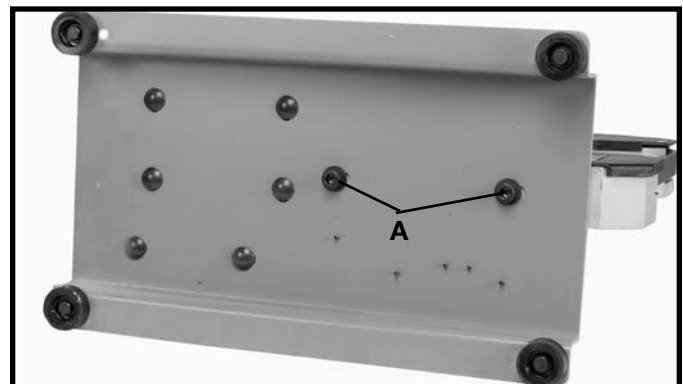

Fig. 2

3. Fig. 3, illustrates the belt unit (D) assembled to the base.



Fig. 3

ASSEMBLING DRIVE BELT AND ADJUSTING BELT TENSION

1. **DISCONNECT MACHINE FROM POWER SOURCE.**

2. Assemble the drive belt (A) Fig. 4, to the two pulleys, as shown.

3. Slide the belt sander frame assembly (B) Fig. 4, forward until there is approximately 1/4 to 1/2 inch deflection in the belt (A) at the center span of the pulleys using light finger pressure.

4. Then tighten the two M10X20mm hex socket head screws (A) Fig. 2, that fasten the belt unit to the base.

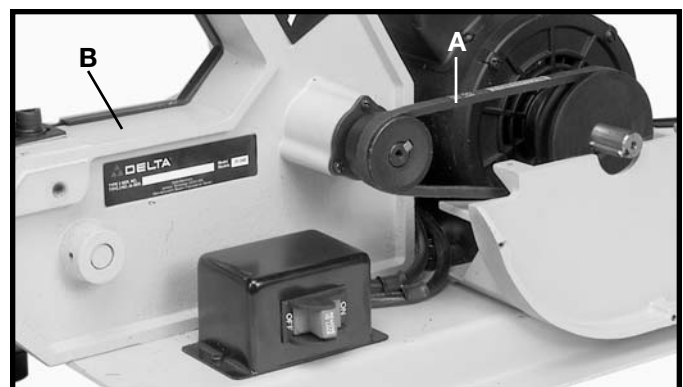

Fig. 4

ASSEMBLING GUARD FOR SANDING DISC AND BELT AND PULLEYS

1. DISCONNECT MACHINE FROM POWER SOURCE

2. Position the guard (A) Fig. 5, in place on the disc unit frame and fasten in place using the two M4X10mm cheese head screws (B) and (C) and two 3/16" flat washers. **NOTE:** Access to screw (C) is through hole (D) in top of guard. Do not completely tighten screws (B) and (C) at this time as the guard must be adjusted to sanding disc plate.

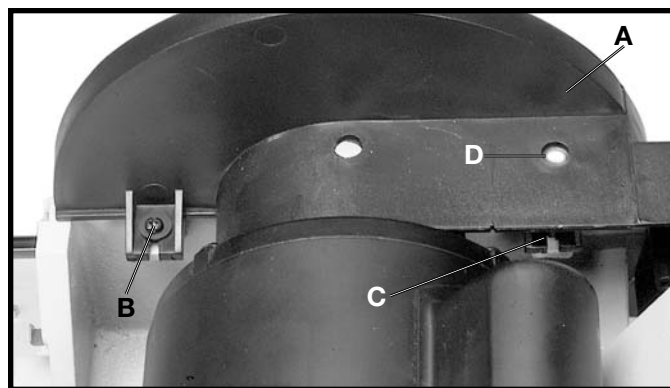

Fig. 5

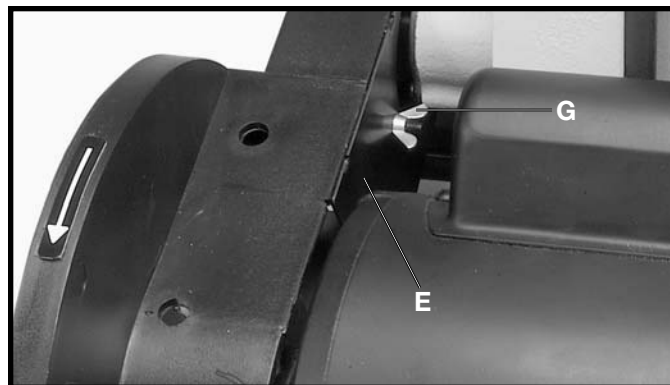

Fig. 6

3. Assemble the inside guard (E) Fig. 6, to the guard assembly using a M4x45mm cheese head screw (F) Fig. 7, and M4 wing nut (G) Fig. 6, as shown.

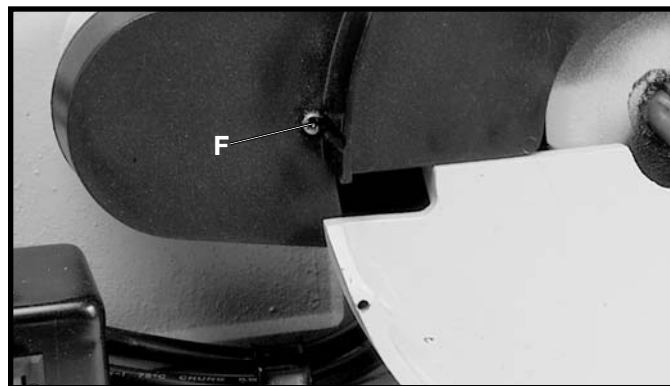

Fig. 7

ASSEMBLING SANDING DISC TO DISC PLATE

1. Make sure the disc plate (A) Fig. 8, is clean.

2. Peel backing from sanding disc and press the sanding disc (B) firmly onto the disc plate (A), as shown in Fig. 8.



Fig. 8

ASSEMBLING SANDING DISC PLATE TO MOTOR SHAFT

1. **DISCONNECT MACHINE FROM POWER SOURCE.**
2. Assemble the sanding disc plate (A) Fig. 9, to the motor shaft with the key (B) in the motor shaft, engaged with the keyway (C) in the hub of the sanding disc.
3. Rotate the sanding disc until the set screw (D) Fig. 9, is in the up position and tighten set screw (D) Fig. 9, using wrench (E) Fig. 10, through the hole (F) in top of guard assembly.
4. Adjust the disc guard so that the lip (G) Fig. 10, covers the outer edge of the sanding disc, but not past the face of the disc, and tighten the two M4X10mm cheese head screws, one of which is shown at (H), that attach the disc guard to the base.

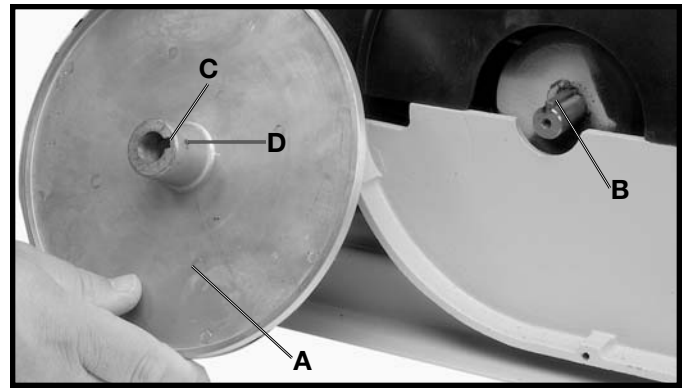

Fig. 9

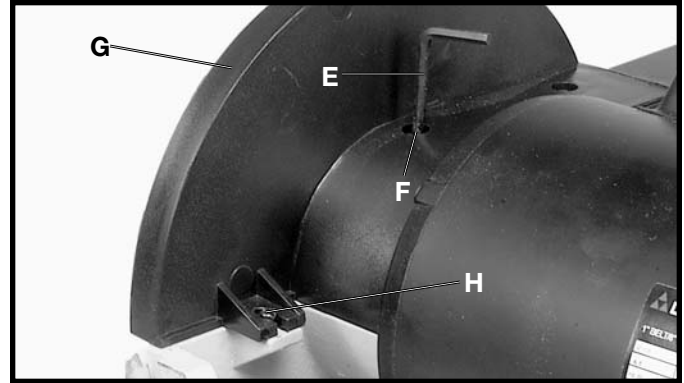

Fig. 10

ASSEMBLING LOWER SANDING DISC GUARD

1. **DISCONNECT MACHINE FROM POWER SOURCE.**
2. Assemble the lower sanding disc guard (A) to the disc base using the three M4X6mm sheet metal screws and washers (B), as shown in Fig. 11.

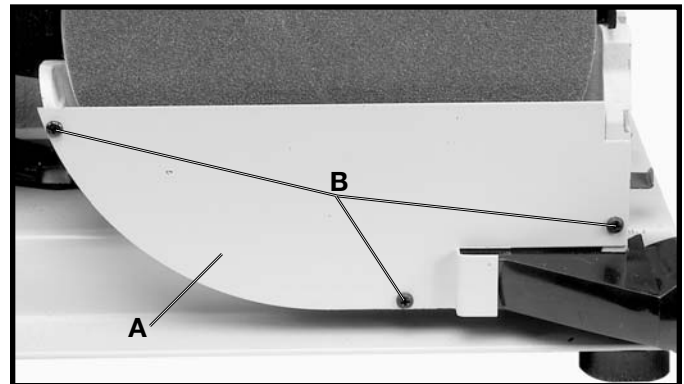

Fig. 11

ASSEMBLING SANDING DISC DUST CHUTE

- Assemble the sanding disc dust chute (A) to the disc sander base using the M6x15mm cheese head screw and 6.4mm external tooth washer (B), as shown in Fig. 12.

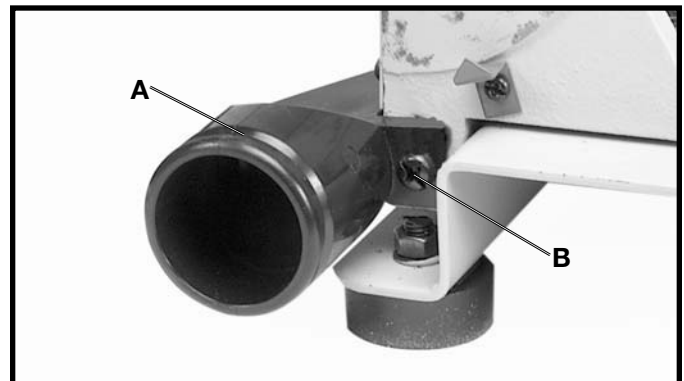

Fig. 12

ASSEMBLING SANDING DISC TABLE

1. **DISCONNECT MACHINE FROM POWER SOURCE.**

2. Two clamp handles are supplied with your machine, one for the belt sander table and one for the disc sander table. Disassemble both handles by unscrewing and removing screw (A), spring (B), and handle (C) from locking stud (D), as shown in Fig. 13.

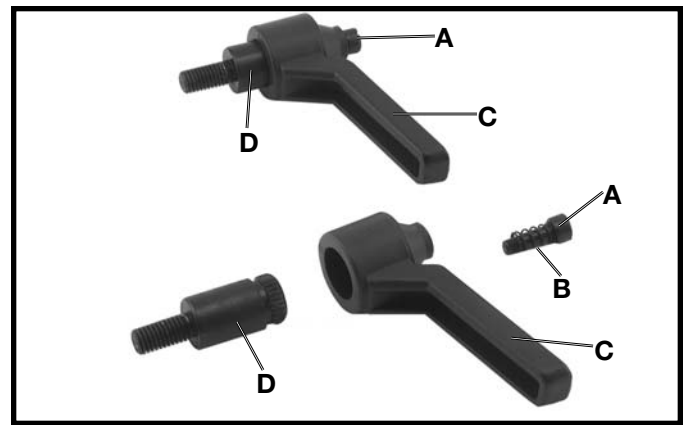

Fig. 13

3. Position the disc table (E) Fig. 14, on the disc base casting, making sure the key (F) on the table bracket is engaged with the keyway (G) on the base casting.

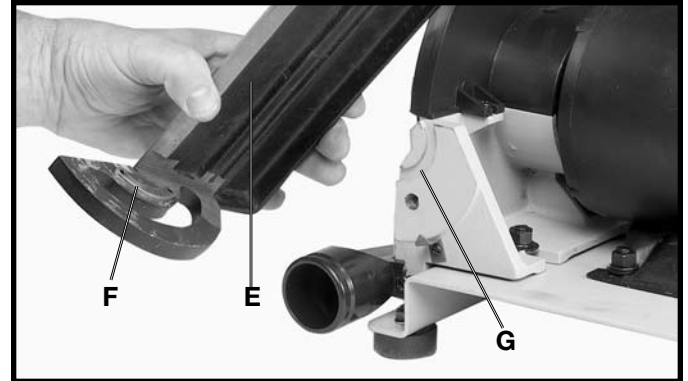

Fig. 14

4. Using locking stud (D) Fig. 13, from handle assembly, and 10mm flat washer (J) Fig. 15, thread locking stud (H) Fig. 15, into threaded hole in base casting to hold table assembly (E) in place, as shown.

5. Assemble handle (C) Fig. 15, to locking stud (H) and fasten with screw (A) and spring (B).

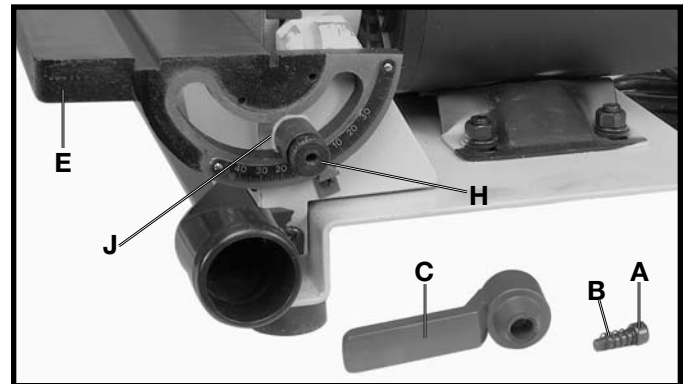

Fig. 15

6. Fig. 16, illustrates the locking handle (C) assembled. **NOTE:** The locking handle (C) is spring-loaded and can be repositioned by pulling out the handle and repositioning it on the serrated stud located underneath the handle.



Fig. 16

ASSEMBLING BELT SANDER TABLE

1. DISCONNECT MACHINE FROM POWER SOURCE.

2. Position the table assembly (A) Fig. 17, in position on the belt sander frame and using locking stud (B), from handle assembly, and flat washer (C), thread locking stud (B) into threaded hole in casting to hold table assembly in place, as shown.

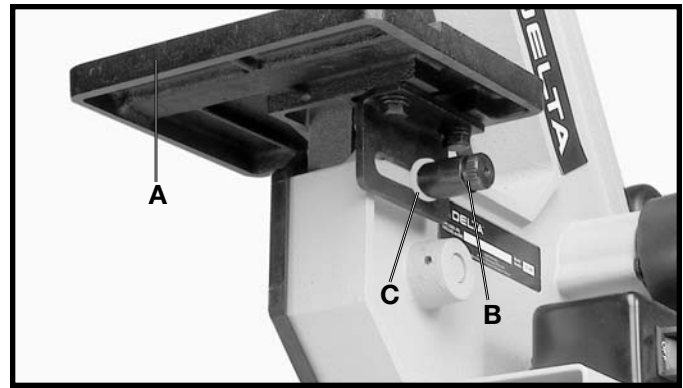

Fig. 17

3. Assemble handle (D) Fig. 18, to locking stud and fasten with screw (E) and spring.

4. **NOTE:** The locking handle (D) Fig. 18, is spring-loaded and can be repositioned by pulling out the handle and repositioning it on the serrated stud located underneath the handle.

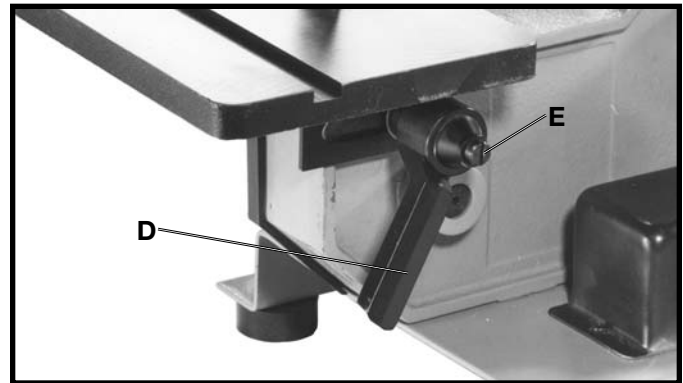

Fig. 18

FASTENING SANDER TO SUPPORTING SURFACE

IF DURING OPERATION THERE IS ANY TENDENCY FOR THE SANDER TO TIP OVER, SLIDE OR WALK ON THE SUPPORTING SURFACE, THE SANDER MUST BE SECURED TO THE SUPPORTING SURFACE. TWO HOLES ARE SUPPLIED IN THE SANDER BASE PLATE FOR MOUNTING.

OPERATING CONTROLS AND ADJUSTMENTS

STARTING AND STOPPING SANDER

The switch (A) Fig. 21, is mounted in a switch box on the sander base. To turn the sander “ON” move the switch (A) to the right position. To turn the sander “OFF” move the switch (A) to the left position.



Fig. 21

LOCKING SWITCH IN THE “OFF” POSITION

IMPORTANT: When the machine is not in use, the switch should be locked in the “OFF” position to prevent unauthorized use. This can be done by grasping the switch toggle (B) and pulling it out of the switch, as shown in Fig. 22. With the switch toggle (B) removed, the switch will not operate. However, should the switch toggle be removed while the sander is running, it can be turned “OFF” once, but cannot be restarted without inserting the switch toggle (B).

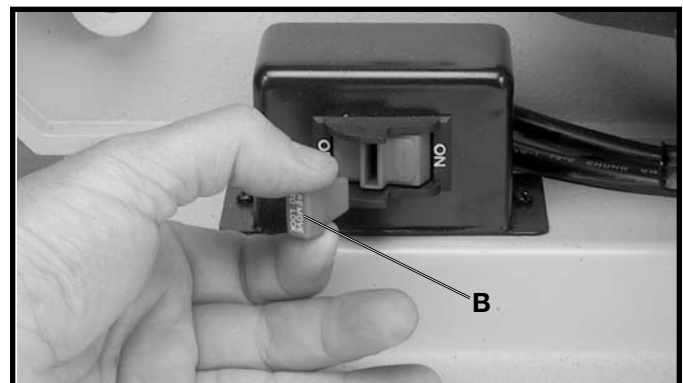

Fig. 22

TRACKING THE SANDING BELT

The belt tracking adjustment is set at the factory so that the belt (A) Fig. 23, will run true on the pulleys. If, however, the belt (A) should lead to one side or the other on the pulleys, an adjustment can be made by turning the tracking knob (B). Turning the knob (B) clockwise will move the belt to the right when facing the sander. Turning the knob (B) counterclockwise will move the belt to the left. **THIS ADJUSTMENT IS USUALLY VERY SLIGHT.**

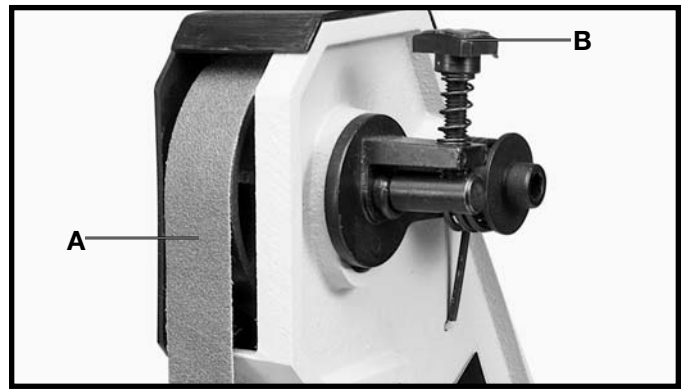

Fig. 23

PLATEN

The platen (A) Fig. 24, is constructed of heavy steel to properly support the work when sanding. The platen should be adjusted so it is almost touching the back of the sanding belt. To adjust the platen, loosen screw (B), adjust the platen to the desired position and tighten screw (B).

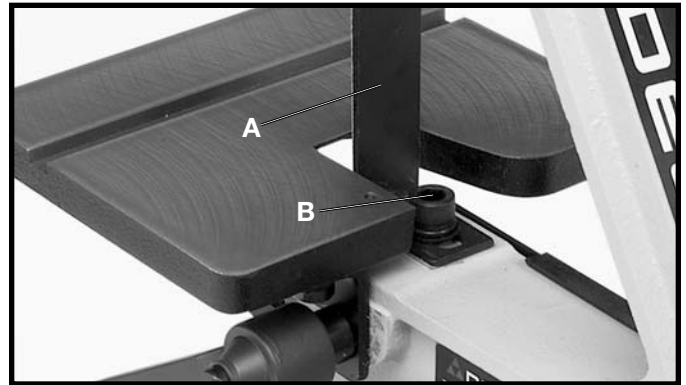

Fig. 24

To remove the platen for operations such as strapping, contour sanding, polishing, or other special operations, remove screw (B) Fig. 24, and remove platen (A).

BELT TABLE ADJUSTMENTS

The belt sander table (A) Fig. 25, can be tilted or moved in or out by loosening lock handle (B), moving the table to the desired position, and tightening lock handle (B). **NOTE:** The lock handle (B) is spring-loaded and can be repositioned by pulling out on the handle and repositioning it on the serrated locking stud located directly under the handle.

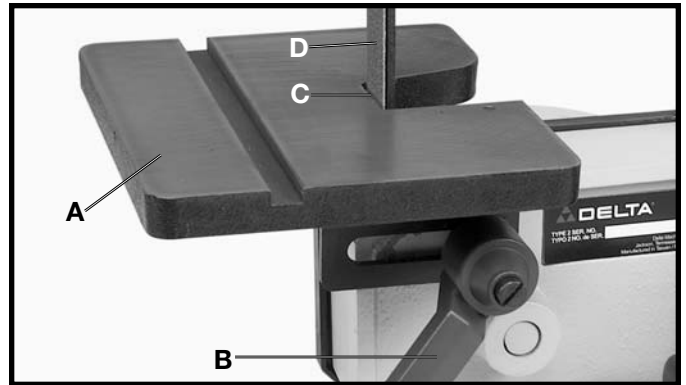

Fig. 25

⚠ WARNING: TO AVOID TRAPPING THE WORK OR FINGERS BETWEEN THE TABLE AND SANDING BELT, THE TABLE EDGE (C) FIG. 25, SHOULD BE POSITIONED A MAXIMUM OF 1/16 INCH FROM SANDING BELT (D) AS SHOWN.

For most sanding operations the table is set at a 90 degree angle to the sanding belt. A positive stop is provided to insure fast positioning of the table at 90 degrees to the belt. Loosen the table lock lever (B) Fig. 26, and tilt the table to the rear as far as possible. Using a combination square (E), place one end of the square on the table with the other end against the sanding belt, as shown, and check to see if the table is 90 degrees to the belt. If the table is not at 90 degrees to the belt, turn adjusting screw with wrench (F). The adjusting screw should bottom against the frame when the table is 90 degrees to the belt.

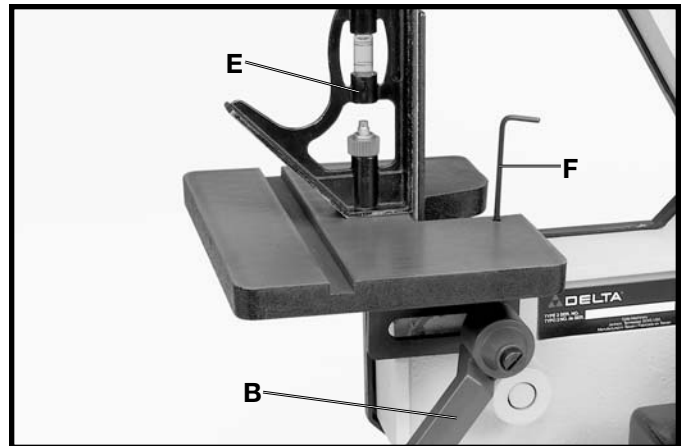

Fig. 26

The table can be tilted 45 degrees to the front, as shown in Fig. 27, by loosening lock lever (B). Using a combination square (E) check to see if the table is at 45 degrees to the belt and tighten lock lever (B).

⚠️ WARNING: TO AVOID TRAPPING THE WORK OR FINGERS BETWEEN THE TABLE AND SANDING BELT, THE TABLE EDGE (C) SHOULD BE POSITIONED A MAXIMUM OF 1/16 INCH FROM THE SANDING BELT (D) WHEN THE TABLE IS TILTED.

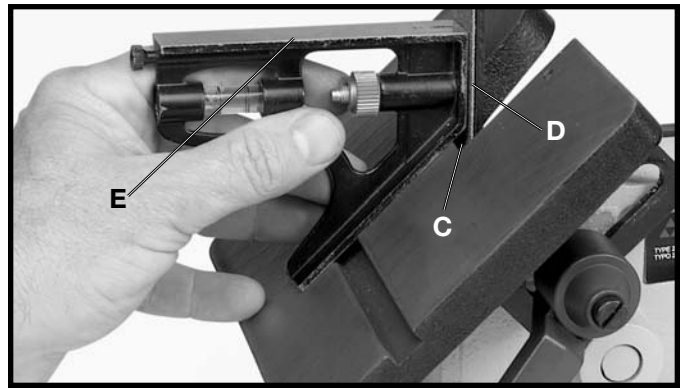

Fig. 27

DISC TABLE ADJUSTMENTS

The disc table (A) Fig. 28, can be tilted 45 degrees up or down, by loosening lock handle (B), tilting the table, and tightening lock handle (B). **NOTE:** The lock handle (B) is spring-loaded and can be repositioned by pulling out the handle (B) and repositioning it on the serrated locking stud located directly underneath the handle.

⚠️ WARNING: TO AVOID TRAPPING THE WORK OR FINGERS BETWEEN THE TABLE AND SANDING DISC, THE SANDING DISC (C) SHOULD BE ADJUSTED SO IT IS A MAXIMUM OF 1/16 INCH FROM EDGE OF TABLE (D). This can be accomplished by moving the sanding disc in or out on the motor shaft.

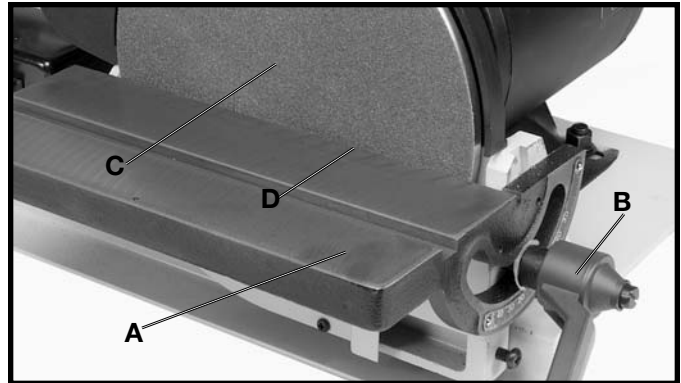

Fig. 28

To check and see if the table is at 90 degrees to the sanding disc, place a square (E) Fig. 29, on the table with one end of the square against the sanding disc, as shown. If an adjustment is necessary, loosen lock lever (B), move table until you are certain it is at 90 degrees to the sanding disc and tighten lock lever (B).

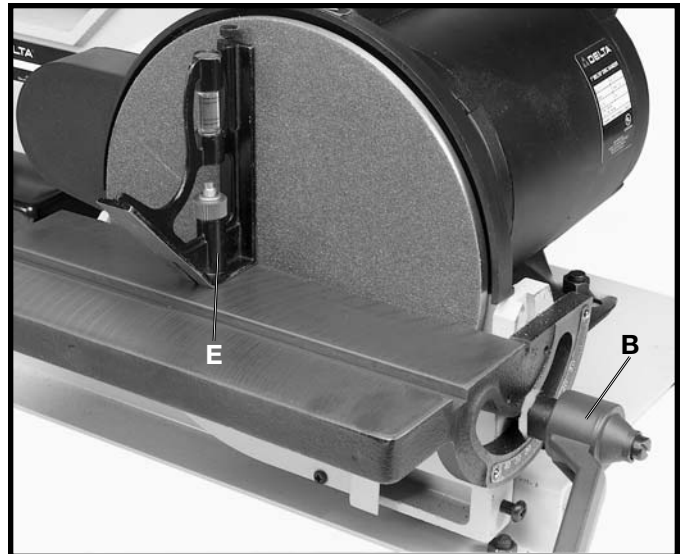

Fig. 29

Then loosen screw (F) Fig. 30, and adjust pointer (G) so it points to the "0" degree mark on the table scale.

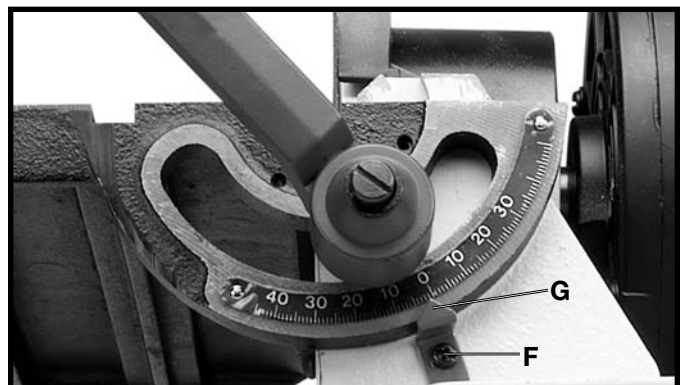

Fig. 30

REMOVING AND INSTALLING ABRASIVE BELTS

1. DISCONNECT MACHINE FROM POWER SOURCE.

2. Unscrew and remove the two knobs (A) Fig. 31, and remove the side cover (B) from the belt unit.

3. Press down on the tracking knob to release belt tension and remove belt (C) Fig. 32, from the three pulleys (D), as shown.

4. Install new 1" x 42" belt and replace side cover. Check belt tracking by referring to the section "TRACKING THE SANDING BELT," and adjust if necessary. **IMPORTANT:** Some belts have a directional arrow printed on the inside of the belt. In these cases the belt must be installed so the directional arrow is in the same direction that the machine is running. The sanding belt travels down at the front of the machine.

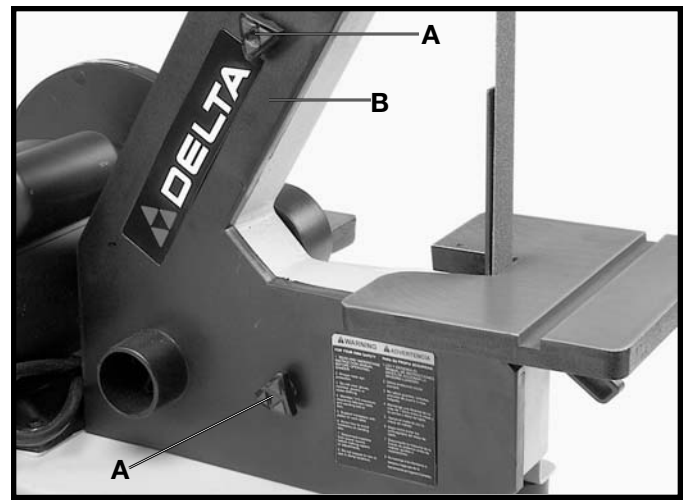

Fig. 31

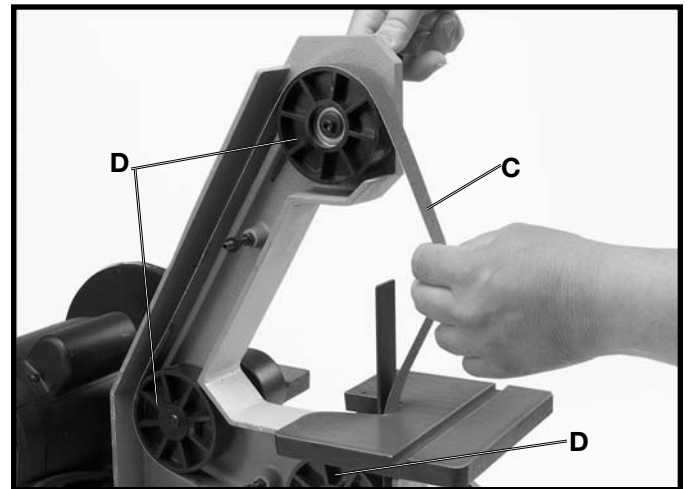

Fig. 32

REMOVING AND INSTALLING ABRASIVE DISCS

1. DISCONNECT MACHINE FROM POWER SOURCE.

2. Remove the sanding disc table.

3. Remove the old abrasive disc by peeling it from the sanding disc plate.

4. Clean the disc plate thoroughly.

5. Remove the backing from the new abrasive disc and press the abrasive disc firmly onto the disc plate.

6. Replace the sanding disc table.

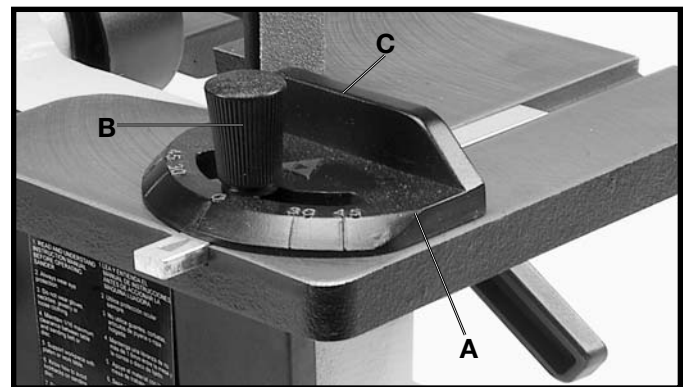

Fig. 33

MITER GAGE

A miter gage (A) Fig. 33, is supplied with your sander and can be used on the disc table, as shown, or on the belt table. The miter gage can be set anywhere up to 45 degrees right or left by loosening lock knob (B), tilting miter gage body (C) to the desired angle and tightening lock knob (B).

DUST CHUTES

Two dust chutes are supplied with your belt and disc sander and are equipped with 1-1/4 inch I.D. openings that can easily be connected to a dust collection system. Dust chute (A) Fig. 34, is for the belt unit and dust chute (B) is for the disc unit.



Fig. 34

TYPICAL OPERATIONS

⚠ WARNING: THE USE OF ATTACHMENTS AND ACCESSORIES NOT RECOMMENDED BY DELTA MAY RESULT IN RISK OF INJURIES.

The following are just some of the many operations that can be performed with your Delta 1" Belt/8" Disc Sander.

Sharpening a cold chisel on the belt unit with the table tilted.

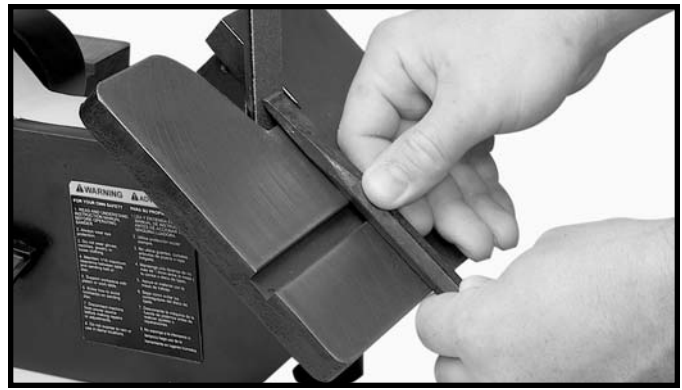

Fig. 35

Sanding aluminum on the disc unit with the table tilted and using the miter gage as a guide. **NOTE:** Always sand on the left (downward) side of the sanding disc, as shown. Sanding on the right (upward) side of the sanding disc could cause the workpiece to fly up, which could be hazardous.



Fig. 36

Sanding outside curves on the belt unit with the platen.



Fig. 37

Sharpening a wood chisel on the belt unit using a block of wood to support the chisel and provide clearance for the chisel handle.

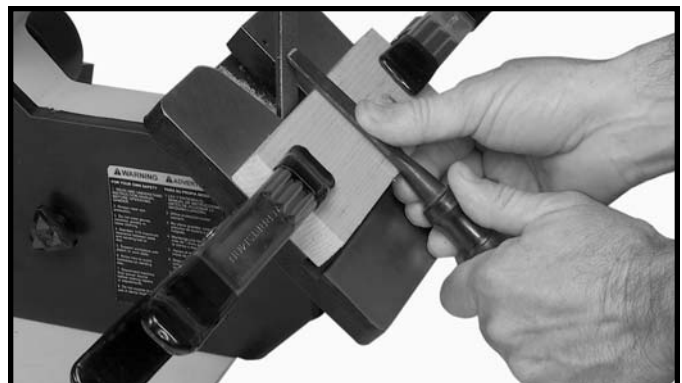

Fig. 38

Polishing using the Delta accessory Felt Belt in place of the sanding belt.

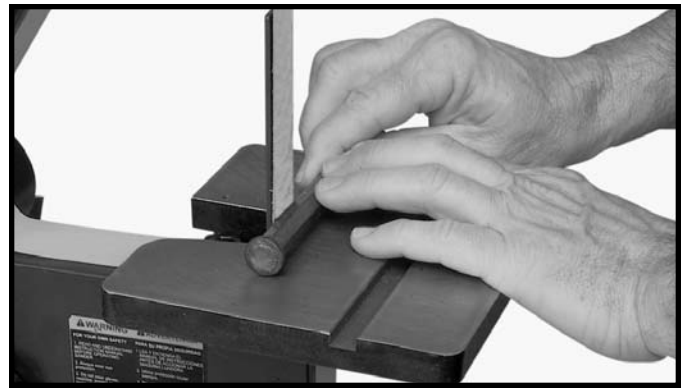

Fig. 39

Sanding in tight areas with the sanding belt.



Fig. 40

Inside curves can be sanded on the top sanding wheel with the side cover removed.



Fig. 41

ACCESSORIES

A complete line of accessories is available from your Delta Supplier, Porter-Cable • Delta Factory Service Centers, and Delta Authorized Service Stations. Please visit our Web Site www.deltamachinery.com for a catalog or for the name of your nearest supplier.

 **WARNING:** Since accessories other than those offered by Delta have not been tested with this product, use of such accessories could be hazardous. For safest operation, only Delta recommended accessories should be used with this product.



PARTS, SERVICE OR WARRANTY ASSISTANCE

All Delta Machines and accessories are manufactured to high quality standards and are serviced by a network of Porter-Cable • Delta Factory Service Centers and Delta Authorized Service Stations. To obtain additional information regarding your Delta quality product or to obtain parts, service, warranty assistance, or the location of the nearest service outlet, please call 1-800-223-7278 (In Canada call 1-800-463-3582).



Two Year Limited Warranty

Delta will repair or replace, at its expense and at its option, any Delta machine, machine part, or machine accessory which in normal use has proven to be defective in workmanship or material, provided that the customer returns the product prepaid to a Delta factory service center or authorized service station with proof of purchase of the product within two years and provides Delta with reasonable opportunity to verify the alleged defect by inspection. Delta may require that electric motors be returned prepaid to a motor manufacturer's authorized station for inspection and repair or replacement. Delta will not be responsible for any asserted defect which has resulted from normal wear, misuse, abuse or repair or alteration made or specifically authorized by anyone other than an authorized Delta service facility or representative. Under no circumstances will Delta be liable for incidental or consequential damages resulting from defective products. This warranty is Delta's sole warranty and sets forth the customer's exclusive remedy, with respect to defective products; all other warranties, express or implied, whether of merchantability, fitness for purpose, or otherwise, are expressly disclaimed by Delta.

NOTES

NOTES