

20-142C 14" ABRASIVE CUT-OFF SAW

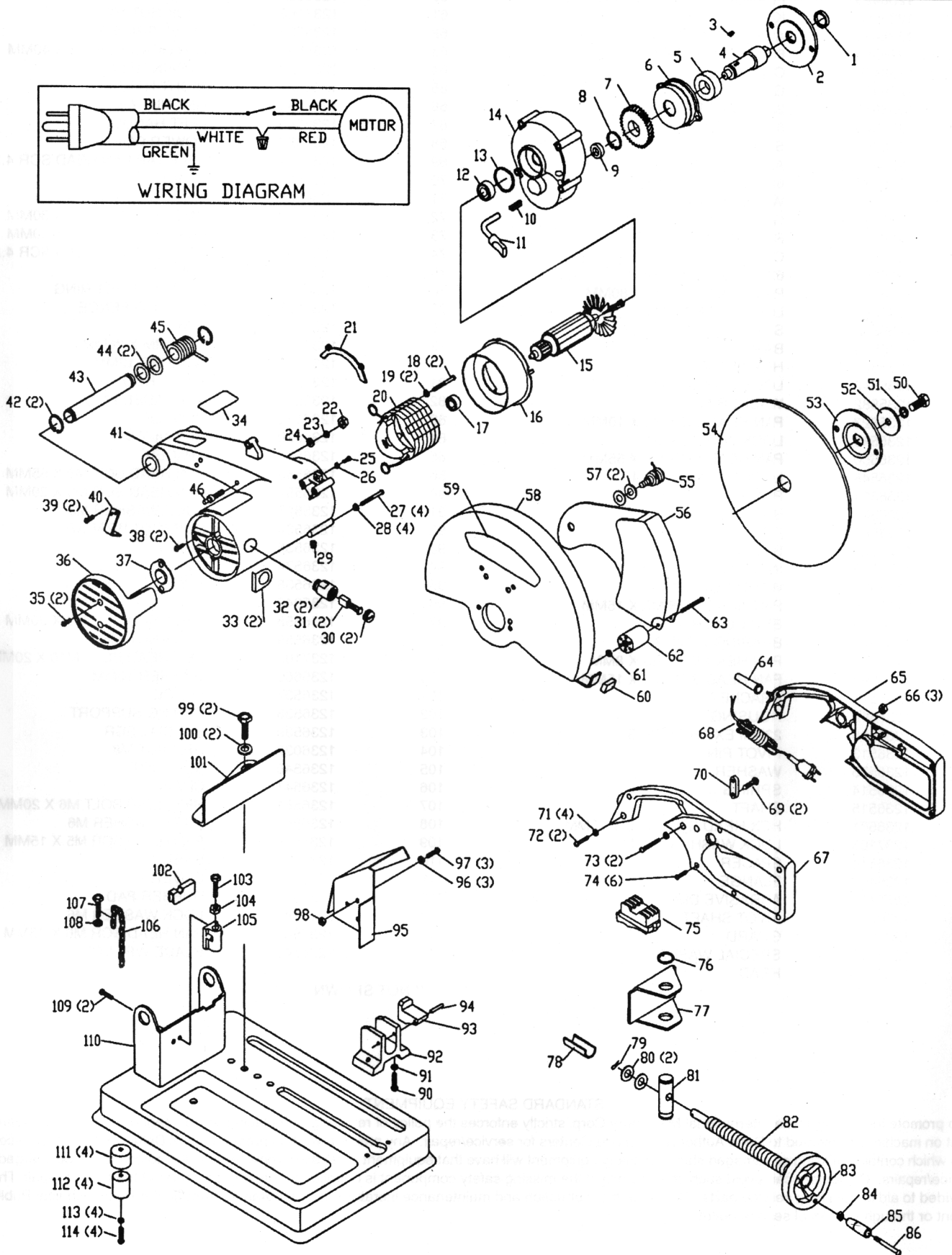
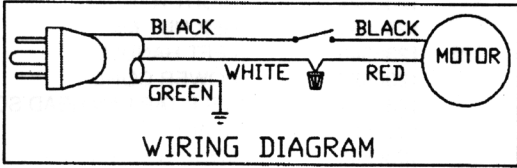

REPLACEMENT PARTS

REF NO.	PART NO.	DESCRIPTION	REF NO.	PART NO.	DESCRIPTION
1	1236492	SLEEVE	59	1236562	NAME PLATE
2	1236493	FLANGE	60	1236521	RUBBER PAD
3	1236563	KEY	61	1237262	LOCK NUT M5
4	1236494	ARBOR SHAFT	62	1236522	PIVOT SPACER
5	1236564	6305 BALL BEARING	63	1236551	PAN HEAD SCR M5 X 40MM
6	1236495	COVER	64	1236523	STRAIN RELIEF
7	1236496	GEAR	65	1236524	RIGHT HANDLE
8	1236565	23MM EXT RET RING	66	1236069	HEX NUT M5
9	1236566	61900 BALL BEARING	67	1236546	LEFT HANDLE
10	1236497	SPRING	68	1236525	POWER CORD
11	1236498	ARBOR LOCK PIN	69	1237779	SELF TAP PAN HEAD SCR 4.2 X 16
12	1236567	6203 BALL BEARING	70	1236526	SPACER
13	1236568	WAVE WASHER	71	1236548	LOCK WASHER M5
14	1236499	GEAR BOX HOUSING	72	1236552	PAN HEAD SCR M5 X 30MM
15	1236500	ROTOR ASSY	73	1236553	PAN HEAD SCR M5 X 50MM
16	1236501	COVER	74	1236554	SELF TAP PAN HEAD SCR 4.2 X 19
17	1236569	6200 BALL BEARING	75	1236527	SWITCH
18	1236547	PAN HEAD SCR M5 x 80MM	76	1236573	21MM EXT RET RING
19	1236548	LOCK WASHER M5	77	1236528	PIVOTING FENCE
20	1236502	STATOR ASSY	78	1236529	SPACER
21	1236503	BAR	79	1236555	PIN 3MM X 26MM
22	1235820	HEX NUT M6	80	1235840	WASHER 12MM
23	1235842	LOCK WASHER M6	81	1236530	PIVOT ROD
24	1235882	WASHER 6MM	82	1236531	THREADED ROD
25	1235823	PAN HEAD SCR M4 X 10MM	83	1236532	HANDLE
26	1236549	LOCK WASHER M4	84	1235820	HEX NUT M6
27	1236550	PAN HEAD SCR M5 X 55MM	85	1236533	SPACER
28	1236548	LOCK WASHER 5MM	86	1236556	PAN HEAD SCR M6 X 55MM
29	1236504	RUBBER SLEEVE	90	1236557	PAN HEAD SCR M8 X 20MM
30	1236505	BRUSH COVER	91	1235825	LOCK WASHER M8
31	1236506	BRUSH	92	1236534	SUPPORT BRACKET
32	1236507	BRUSH HOLDER	93	1236535	BRACKET
33	1236570	INSULATOR	94	1236574	3MM x 35 ROLL PIN
34	1236508	WARNING LABEL	95	1236536	SPARK DEFLECTOR
35	1235898	PAN HEAD SCR M5 X 15MM	96	1235842	LOCK WASHER M6
36	1236509	END COVER	97	1236558	PAN HEAD SCR M6 X 20MM
37	1236510	BEARING COVER	98	1236559	LOCK NUT M6
38	1235869	PAN HEAD SCR M5 X 8MM	99	1237102	HEX HEAD BOLT M10 X 20MM
39	1235898	PAN HEAD SCR M5 X 15MM	100	1235660	WASHER 10MM
40	1236511	BRACKET	101	1236537	FENCE
41	1236512	HOUSING	102	1236538	SPRING SUPPORT
42	1236565	23MM EXT RET RING	103	1236539	SPECIAL SCR
43	1236513	PIVOT PIN	104	1236037	HEX NUT M8
44	1236575	WASHER	105	1236540	SUPPORT
45	1236514	SPRING	106	1236541	CHAIN
46	1236515	SHAFT	107	1236561	HEX HEAD BOLT M6 X 20MM
50	1236571	HEX HEAD BOLT M10 X 25MM	108	1235842	LOCK WASHER M6
51	1237103	LOCK WASHER 10MM	109	1235898	PAN HEAD SCR M5 X 15MM
52	1236516	SPACER	110	1236542	BASE
53	1236493	FLANGE	111	1236543	COVER
54	OPTIONAL	ABRASIVE DISC	112	1236544	RUBBER PAD
55	1236572	PIVOT SHAFT	113	1235842	LOCK WASHER M6
56	1236518	GUARD	114	1236560	PAN HEAD SCR M6 X 25MM
57	1236519	SPECIAL WASHER	**	1236545	BLADE WRENCH
58	1236520	HEAD			

** NOT SHOWN

STANDARD SAFETY EQUIPMENT

In order to promote tool safety, Delta International Machinery Corp. strictly enforces the policy of repairing or replacing any damaged or missing standard safety equipment on machines presented to Delta Authorized Service Centers for service/repair. Any product which is presented to a Delta Authorized Service Center for repairs which contains missing or damaged standard safety equipment will have that equipment repaired or replaced and the customer will be charged for any such service/repairs. Customers can avoid such charges only if the missing safety component is supplied to the service center at the time of repair. This parts list is provided to aid in obtaining service parts. Copies of the instruction and maintenance literature can be obtained through the Delta Technical Publications Department or through your local service outlet.