

REPLACEMENT PARTS

<u>Ref.</u>	<u>No.</u>	<u>Part No.</u>	<u>Description</u>	<u>Ref.</u>	<u>No.</u>	<u>Part No.</u>	<u>Description</u>
	1	901169	UPPER PULLEY COVER	55	1243496		M10 HEX NUT
	1A	901180	SPEED CHART, T2	56	1311045		SPRING SEAT
		1340061	SPEED CHART, T1	57	1310082		SPRING ASSEMBLY
	2	1310065	KNOB	57A	1311046		SPRING RETAINER
	3	1310057	STRAIN RELIEF	58	902-01-020-1227		1/2-20 HEX NUT
	4	1246045	M6 X 10MM CHEESE HD SCREW	59	1313047		1/2-20 HEX NUT
	5	1243569	M4 HEX NUT, T2	60	1312025		SWITCH BOX
		1243456	M6 HEX NUT, T1	61	1246001		M5 X 12MM CHEESE HD SCREW
	6	1320102	M4.3 EXT TOOTH WASHER, T2	62	1311084		COVER
		1310062	M6.4 FLAT WASHER, T1	62A	1340720		INSULATOR
	7	1310056	GROMMET	63	1310070		M4.8 X 16MM PAN HD SCREW (E.M.O.)
	7A	1243501	M4 X 10MM CHEESE HD SCREW, T2		1310547		M4.2 X 12MM PAN HD SCREW (C.M.O.)
		1246002	M6 X 12MM CHEESE HD SCREW, T1	63A	901337		HARDWARE PACK
	8	901170	L/PULLEY COVER W/HINGES, T2	64	1343759		SWITCH, INCL:
		1312032	L/PULLEY COVER W/HINGES, T1	66	1343758		SWITCH KEY (NOTE B)
	9	901338	NAMEPLATE, T2	67	1311056		NUT
		1340063	NAMEPLATE, T1	68	1311055		RING
	10	1312016	SLEEVE	69	1311054		M17.5 FLAT WASHER
	11	1312019	RETAINING RING	70	920-04-020-5335		BEARING
	12	1312017	BEARING	71	1312014		RUBBER WASHER
	13	1312018	SPACER	72	1312013		QUILL
	14	1312030	V-BELT SET	72A	1311065		SHIFTER
	15	1312028	BEARING	73	1312053		BEARING
	16	1312027	PULLEY	74	1312015		SPINDLE
	17	1312029	SHAFT	75	1312021		ARBOR
	18	1311071	KEY	76	1312022		5/8" CHUCK, INCL:
	19	1312024	PULLEY	*	1313105		CHUCK KEY
	20	1246133	M8 X 8MM HEX SOC SET SCREW	77	901168		RING, T2
	21	1311061	NUT		1312009		RING, T1
	22	1312020	PULLEY	78	1243321		M6 X 10MM HEX SOC SET SCREW
	23	1312023	MOTOR	79	901167		TABLE BRACKET ASSY, INCL:
	24	1246034	M8 X 20MM HEX HD SCREW	80	1311007		PINION GEAR
	25	1243476	M12 HEX NUT	81	1311008		SHAFT
	26	904-02-020-1705	1/2" LOCK WASHER	82	1311016		INDICATOR
	27	1311029	BRACKET	83	1310016		5MM DRIVE SCREW
	28	1312012	ROD	84	901176		SCALE, T2
	29	1312031	ROD		1311015		SCALE, T1
	30	1311069	M9.8 FLAT WASHER	85	1311012		BOLT
	31	1243398	M8 HEX NUT	86	1310013		THREADED PIN
	32	1311067	MOTOR CORD	87	902-01-120-1034		1/4-20 HEX NUT
	33	1311072	POWER CORD	88	1311017		HANDLE
	34	901172	HEAD BODY (C.M.O. NOTE C), T2	89	n A06912		WORM GEAR
		1312090	HEAD BODY (C.M.O. NOTE C), T1	90	1344257		HANDLE ASSY
	34A	1312010	HEAD BODY (E.M.O. NOTE C)	91	1243321		M6 X 10MM HEX SOC SET SCREW
	34B	1246110	M6 X 24MM SPRING PIN (C.M.O.)	92	1311018		HANDLE W/STUD
	35	1310016	5MM DRIVE SCREW	93	901166		TABLE, T2
	36	900417	WARNING LABEL, T2		1312007		TABLE, T1
		1345946	WARNING LABEL, T1	95	1310595		COLUMN ASSY, INCL: (C.M.O. NOTE C)
	37	901171	LOCK SCREW, T2	95A	1310095		COLUMN ASSY, INCL: (E.M.O. NOTE C)
		1311028	LOCK SCREW, T1	96	1311003		M10 X 12MM HEX SOC SET SCREW
	38	1246139	M8 X 18MM HEX HD SCREW	97	1312008		RACK
	39	1311026	ECCENTRIC	98	1312001		BASE
	40	1312011	HANDLE	99	1246029		M10 X 40MM HEX HD SCREW (C.M.O.)
	41	1311003	M10 X 12MM HEX SOC SET SCREW		901-01-060-0615		7/16-14 X 1 3/4" HEX HD SCREW (E.M.O.)
	42	1311039	GRIP	100	428-06-101-0002		3MM HEX WRENCH
	43	1311038	HANDLE	101	432-07-101-0004		5MM HEX WRENCH
	44	1311036	KEY	102	1344329		M8 X 125MM CARRIAGE HD SCREW
	45	1310085	PINION ASSY, INCL;	103	1344330		M8 FLAT WASHER
	46	1311034	PIN	104	1246157		M8.1 LOCK WASHER
	47	1311037	LOCK SCREW	105	1243398		M8 HEX NUT
	48	1311040	STOP RING	106	1342455		M5 X 10MM PAN HD SCREW, T2
	49	1310016	5MM DRIVE SCREW	107	1340719		CLAMP, T2
	50	901174	SCALE, T2	108	1343304		1/4" RUBBER WASHER, T2
		1311041	SCALE, T1	109	1320101		M5.3 EXT TOOTH WASHER, T2
	51	1311035	STOP PIN	110	1310155		M5 X 8MM CHEESE HD SCREW, T2
	52	1310016	5MM DRIVE SCREW				
	53	900435	POINTER, T2	**	NOT SHOWN		
		1311042	POINTER, T1		EMO=EARLY MODELS ONLY		
	54	1311048	SPECIAL SCR		CMO=CURRENT MODELS		

REPLACEMENT PARTS

NOTE B: DELTA HAS USED A NUMBER OF DIFFERENT TYPES OF SWITCHES FOR PRODUCTION. ALL SWITCHES ARE INTERCHANGEABLE BUT THE KEYS ARE DIFFERENT. REPLACEMENT SWITCHES COME COMPLETE WITH KEY, IF A REPLACEMENT KEY IS NEEDED, REFER TO DRAWING BELOW TO SELECT THE PROPER ONE.

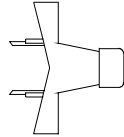
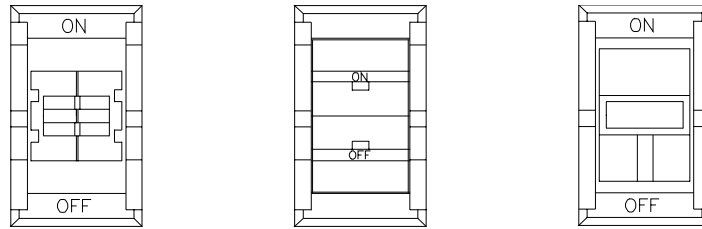

400-06-068-0001

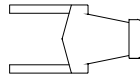

400-06-068-0002

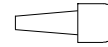

1343758

NOTE C: EARLY MODEL HEADS WERE BORED TO ACCEPT 78MM COLUMNS (REF. NO. 95A) CURRENT STYLE HEADS ARE BORED TO ACCEPT 80MM COLUMNS (REF. NO 95). EARLY COLUMNS (REF. NO. 95A) ARE STEPPED AT THE TOP, EARLY AND CURRENT MODELS ARE NOT INTERCHANGEABLE. WHEN REPLACING 34A OR 95A, USE ONE EA. OF REF. 95, REF. 34 T1 , & REF. 34B.

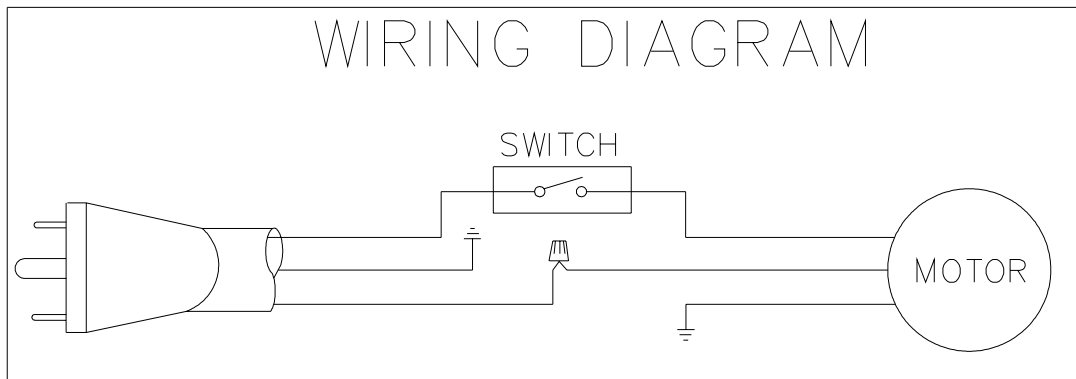

STANDARD SAFETY EQUIPMENT

In order to promote tool safety, Delta Machinery strictly enforces the policy of repairing or replacing any damaged or missing standard safety equipment on machines presented to Delta Authorized Service Centers for service/repairs. Any product that is presented to a Delta Authorized Service Center for repair with damaged or missing standard safety equipment will have that equipment repaired or replaced and the customer will be charged for any such service/repairs. Customers can avoid such charges only if the missing safety component is supplied to the service center at the time of repair.

This parts list is provided to aid in obtaining service parts. Copies of the instruction and maintenance literature can be obtained through the Delta Technical Publications Department, your service outlet, or by visiting the Delta Website @ www.deltamachinery.com.