

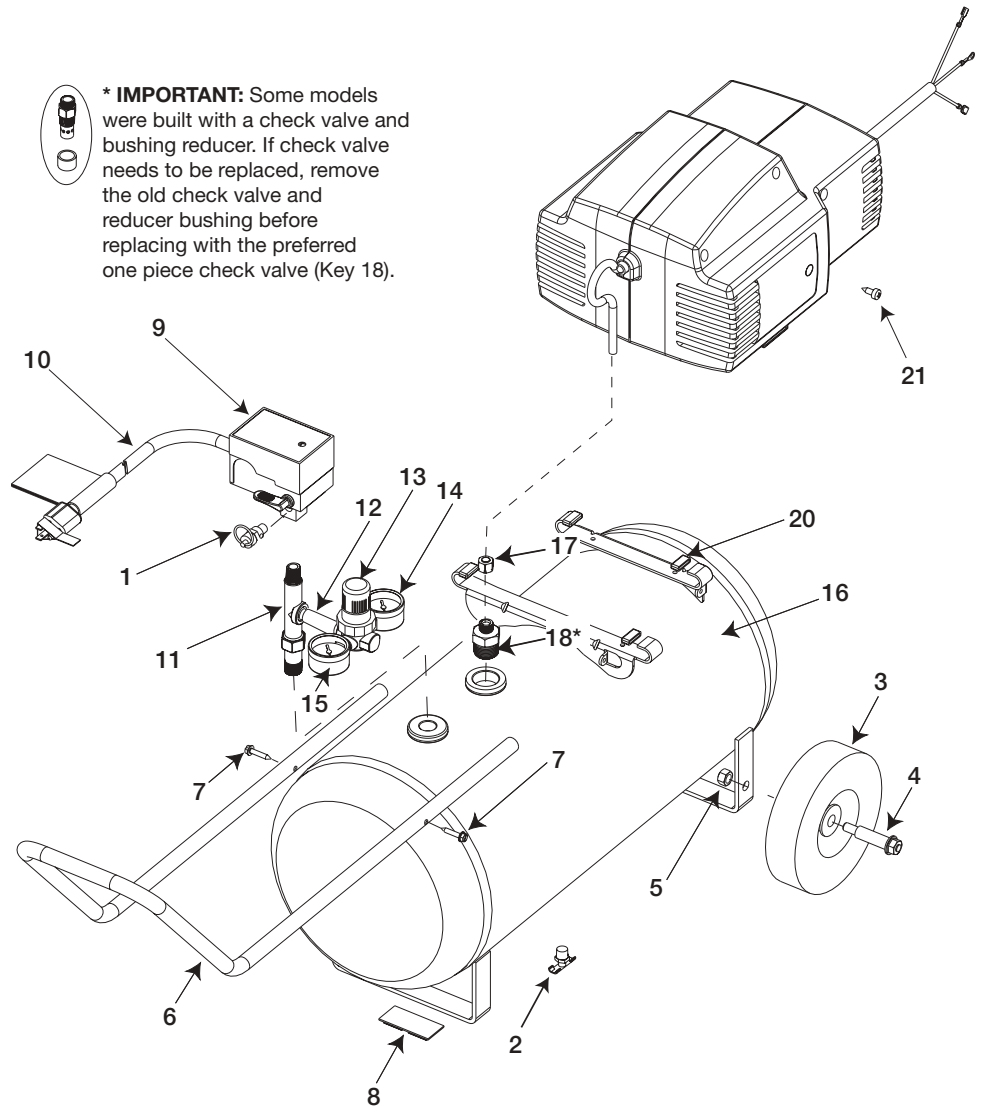

CP503-2 Oilfree Air Compressor

PART NO. A03342 r1
Date: 5/5/04



*** IMPORTANT:** Some models were built with a check valve and bushing reducer. If check valve needs to be replaced, remove the old check valve and reducer bushing before replacing with the preferred one piece check valve (Key 18).

Ref. No.	Part No.	Description	Ref. No.	Part No.	Description
1	TIA-4150	Safety Valve	12	D30198	Nipple 1/4 x 1/4 NPT x 2.50
2	D23000	Drain Valve	13	D27256	Regulator
3	D23138	Wheel 9" (2)	14	Z-AC-0009-1	Gauge - Right Hand
4	CAC-60	Shoulder Bolt (2)	15	Z-AC-0010-1	Gauge - Left Hand
5	SSF-8080-ZN	Nut Hex 3/8-16 (2)	16	Z-D26922	Tank
6	AC-0345	Handle	17	SSP-473	Nut Sleeve
7	SSF-612	Screw #10-16 x 1.00 (2)	18	D29264	Check Valve
8	AC-0364	Molded Foot Bumper	20	* CAC-1254	Isolator (4)
9	Z-D27227	Pressure Switch	21	* SSF-621	Screw 1/4-14 x .625 (2)
10	D26615	Cord Assembly			
11	D28999	Manifold			

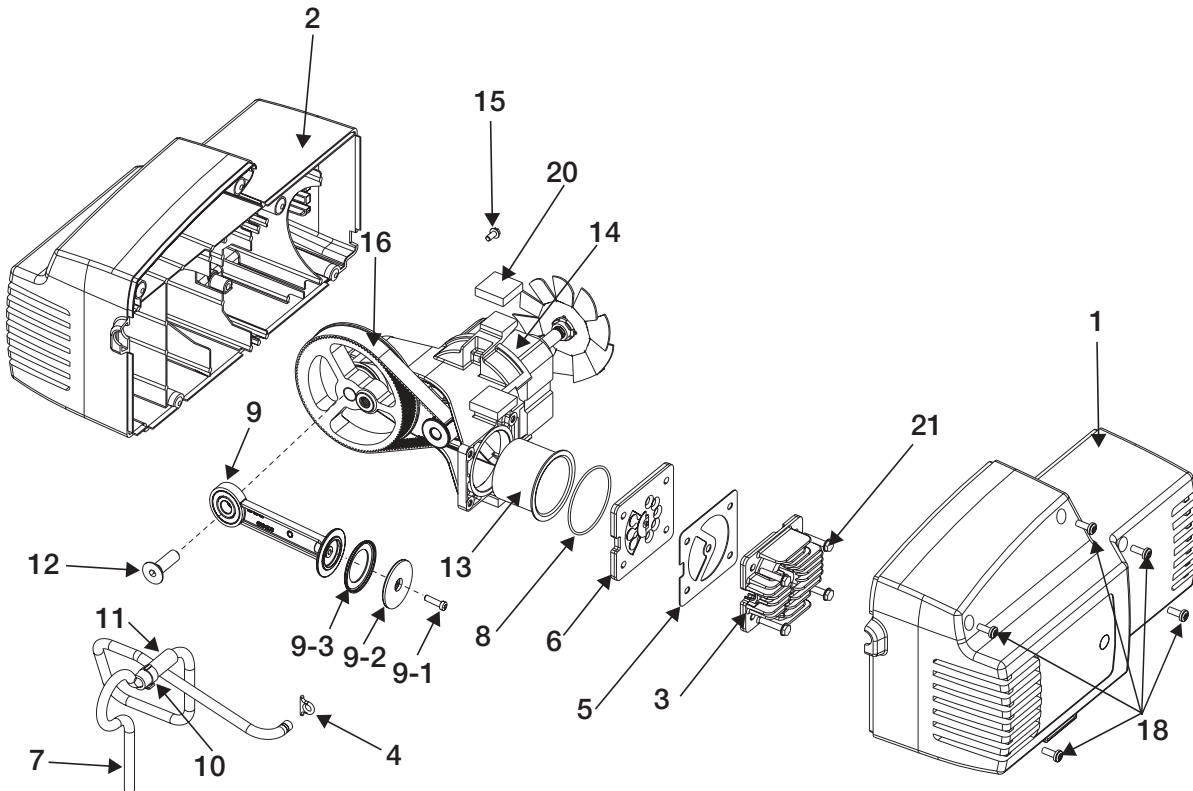

Ref. No.	Part No.	Description
1	A02377	Shroud, Left
2	A02378	Shroud, Right
3	CAC-1196	Cylinder Head
4	* CAC-1212	Tube Seal
5	* Z-D24819	Gasket Head
6	Z-D29777	Valve Plate Assembly
7	D27586	Outlet Tube
8	* SSG-8169	O-ring
9	▲+ ————	Rod Assembly
9-1	▲● D21127	Screw #10-24
9-2	▲ ————	Connecting Rod Cap
9-3	▲● ————	Pre-Formed Compression Ring
10	CAC-1206-1	Clamp
11	AC-0206	Isolator Tube
12	▲x SSF-3147	Screw 3/8-16 x .375
13	●+ ————	Cylinder Sleeve
14	▲ ————	Endbell Assembly
15	x SUDL-9-1	Screw 8-32 x .375/.344
16	▲ AC-0815	Timing Belt
18	x SSF-3156	Screw, 10-9 x.500 Plastite (5)
20	* D25731	Pump Isolator (5)
21	x SSF-995	Screw #10-24 x .875 (4)

Not Shown

A00765

Motor Cord

Kits Available

* D29803

Isolator Kit

+ KK-4964

Connecting Rod Kit

x KK-4929

Fastener Kit

● D30324

Ring Kit

▲ Z-A04647

Sub Pump Assembly

Replacement Brushes for Motor

Before ordering a replacement brush make sure you have the correct motor part number. The motor part number is stamped on the motor stack, match this number to the brush listed below.

Motor

D29398

Brush

uses Z-D23825

D30106

uses Z-A02125