

REPLACEMENT PARTS

Ref. No.	Part No.	Description	Ref. No.	Part No.	Description
1	417-89-363-0005	Table Insert Incl.:	*	34-895	Miter Gage, Const. of:
2	901-02-321-8010	#10-32 Flat Hd. Mach. Screw	84	931-02-010-1085	Handknob
3	1231395	#10 Push Nut	85	904-07-010-5555	Fiber Washer
4	901-04-150-1186	#10 - 32 X 1/4" Soc. Set Screw	86	901-04-410-4561	1/4 - 20 X 1/4" Headless Set Scr.
5	417-89-091-0002	Table	87	422-01-050-0001	Gage Body
6	417-91-004-0001	Guide Rail (Rear)	88	902-01-200-1086	#8 - 32 Hex Nut (Early Models Only)
7	417-89-004-0001	Guide Rail (Front)	89	901-04-121-3615	#8 - 32 X 1/2" Fil. Hd. Screw
8	901-02-050-0735	5/16 - 18 X 1-1/2" Fil. Hd. Screw	90	901-07-261-3237	Stud
9	422-16-104-0001	Spacer	91	417-97-075-0002	Pointer
10	904-02-010-1703	5/16" Lockwasher	92	905-04-061-2351	Steel Pin
11	902-01-010-1300	5/16 - 18 Hex Nut	93	422-01-088-0002	Stop Link
12	417-89-109-0001	Table Extension	94	422-01-112-0001	Pivot Screw
13	429-02-314-0130	Motor	95	417-89-004-0003	Bar
14	34-105	10" Blade, 5/8" Hole	96	901-02-010-0564	#6-32 x 3/8" Rd. Hd. Mach. Screw
15	412-01-103-5004	Arbor Flange	*	422-04-343-5005	Rip Fence, Complete, Const. of:
16	902-01-201-2567	5/8" L.H. Arbor Nut	104	1087198	Front Clamp Block Assy., Inc.:
17	429-01-001-0102	Front Cover	105	1087212	Clamp
18	1087418	Rear Cover	106	904-01-031-7720	21/64 X 1/2 X .031" Washer
19	901-06-121-7383	#10 - 24 X 3/8" Rd. Hd. Screw	107	901-02-010-0551	#10 - 32 X 1/4" Rd. Hd. Screw
20	438-01-017-0118	Switch (See Note A), Incl.:	108	422-16-075-0003	Pointer
21	400-06-068-0001	Switch Key (See Note A)	109	1087531	Handknob
20	438-01-017-0140	Switch (See Note A), Incl.:	110	904-01-010-1603	1/4 X 9/16 X 3/64" Washer
21	400-06-068-0002	Switch Key (See Note A)	111	1087534	Knob
22	1087493	Jumper Wire	112	901-01-060-9929	3/8 - 24 X 5/8" Hex. Hd. Screw
23	438-01-004-0062	Heyco Bushing	113	904-01-030-1650	Special Washer
24	438-01-007-0042	Wire Nut	114	422-04-343-5004	Fence
25	1087496	Power Cord	115	901-01-060-0605	5/16 - 18 X 1/2" Hex. Hd. Screw
26	438-01-017-0154	Overload	116	904-01-010-1604	5/16 X 3/4 X 1/16" Washer
27	438-01-015-0027	Relay	117	422-04-010-5002	Rear Clamp Block
28	1225324	Capacitor	118	905-04-071-4459	Pin
29	429-01-004-0108	Clamp	119	928-01-041-4118	Spring
30	1087714	Ground Wire	120	422-03-027-0001	Rear Clamp Hook
31	901-06-121-7383	#10-24 x 3/8" Rd. Hd. Screw	121	422-04-067-5001	Lever
31A	904-03-030-1795	#10 Ext. Tooth Lockwasher	122	422-16-108-0002	Rod
32	902-02-040-1306	1/4 - 20 Sq. Nut	*	1087468	Blade Guard, Const. of:
33	901-01-060-0614	1/4 - 20 X 1-1/4" Hex. Hd. Screw	132	1086334	"See Thru" Guard
34	904-02-020-1702	1/4" Lockwasher	133	1087811	Pin
35	904-01-010-1604	1/4" Washer	134	1086388	Push Nut Cap
36	417-89-014-0001	Motor Bracket	135	1086353	Spring
37	1231350	5/16" X 5/8" Groove Pin	136	422-16-047-0001	Kickback Finger
38	417-89-135-0001	Elevating Link	137	1086337	Pivot Bracket
39	417-89-088-0001	Stop Washer	138	422-16-071-0002	Pin
40	905-01-010-2711	1/8" x 5/8" Roll Pin	139	1086387	Push Nut
41	1231348	Elevating Nut	140	905-01-012-0311	1/4 X 11/16" Roll Pin
42	417-89-106-0002	Elevating Shaft, Current Model starting with serial #GU210616 (See Note B)	141	1087467	Splitter w/ Bushings
42	417-89-106-0001	Elevating Shaft, Early Model prior to serial #GU210616 (See Note B)	142	904-01-010-1603	1/4" Flat Washer
43	905-02-081-8114	1/8" X 9/16" Groove Pin	143	901-01-060-0611	1/4 - 20 X 1/2" Hex. Hd. Screw
44	417-89-071-0001	Pivot Pin	144	422-18-014-0001	Splitter Bracket
45	928-05-001-4106	Spring Washer	145	1087577	1/2 X 3/4 X 1/16" Washer
46	417-89-095-0002	Trunnion, Current Model starting with serial #GU210616 (See Note B)	146	902-01-020-1266	1/2 - 13 Hex Nut
46	417-89-095-0001	Trunnion, Early Model prior to serial #GU210616 (See Note B)	149	1087708	Blade Arbor Wrench
47	1230415	Collar, Incl.:	* Shown Not Assembled		
47A	901-04-150-0231	5/16 - 18 x 3/8: Hex Soc. Set Screw	Service Note A - Switch Key, Part #406-06-068-0001, fits Switch, Part #438-01-017-0118, only, which is used on saws prior to Serial Number GU-200595.		
48	1231349	Spacer	Switch, Part #438-01-017-0140, including Switch Key, Part #400-06-068-0002, used on saws, Serial Number GU-200595, and higher, can replace complete Switch, Part #438-01-017-0118. Switch keys are not interchangeable.		
49	901-01-060-0611	1/4 - 20 X 1/2" Hex. Hd. Screw	SERVICE NOTE B - A Trunnion and Elevating Shaft modification was incorporated in units starting with serial #GU210616. Early model parts 417-89-106-0001 and 417-89-095-0001, must be used in units with serial #'s prior to GU210616. Current model parts 417-89-106-0002 and 417-89-095-0002, must be used in units starting with serial #GU210616 and up. The current style Trunnion and Elevating Shaft will not adapt to early model saws even as a set.		
50	904-01-010-1614	1/4" Washer			
51	417-89-075-0002	Tilt Pointer			
52	438-01-004-0015	Cable Clamp			
53	901-04-150-1112	3/8 - 16 X 1/2" Soc. Set Screw			
54	904-18-042-1594	Vinyl Retaining Ring			
55	417-89-089-0002	Support Rod			
56	902-01-020-5438	7/16" - 14 Hex Jam Nut			
57	902-06-011-8569	Tilt Nut			
58	417-97-406-0005	Tilt Shaft Assy.			
59	417-89-014-0002	Trunnion Bracket			
60	901-01-060-0607	5/16 - 18 X 3/4" Hex. Hd. Screw			
61	904-02-020-2086	5/16" Lockwasher			
62	904-01-010-1605	5/16" Washer			
63	1231287	1/4 - 10 X 1/2" Hx. Hd. Plastite Scr.			
64	417-89-438-0001	Handwheel Assy.			
65	904-01-010-1615	5/16" Washer			
66	1230871	Knob			
67	417-89-318-0002	Cabinet Assy., Incl.:			
68	417-89-031-0002	Cover			
69	417-89-071-0002	Push-In Pin			
70	417-89-f37-0002	Nameplate w/scale			
71	417-89-017-0001	Bushing			
72	901-01-060-0605	5/16 - 18 X 1/2" Hex. Hd. Screw			
73	904-02-020-2086	5/16" Lockwasher			
74	904-01-010-1604	5/16" Washer			
75	901-06-120-3020	#6 X 3/8" Self Tapping Scr.			
76	901-02-010-0527	1/4 - 20 X 2-1/4" Rd. Hd. Mach. Scr.			
77	1231378	1/4 - 20 Hex Lock Nut			
78	417-89-104-0003	Spacer			

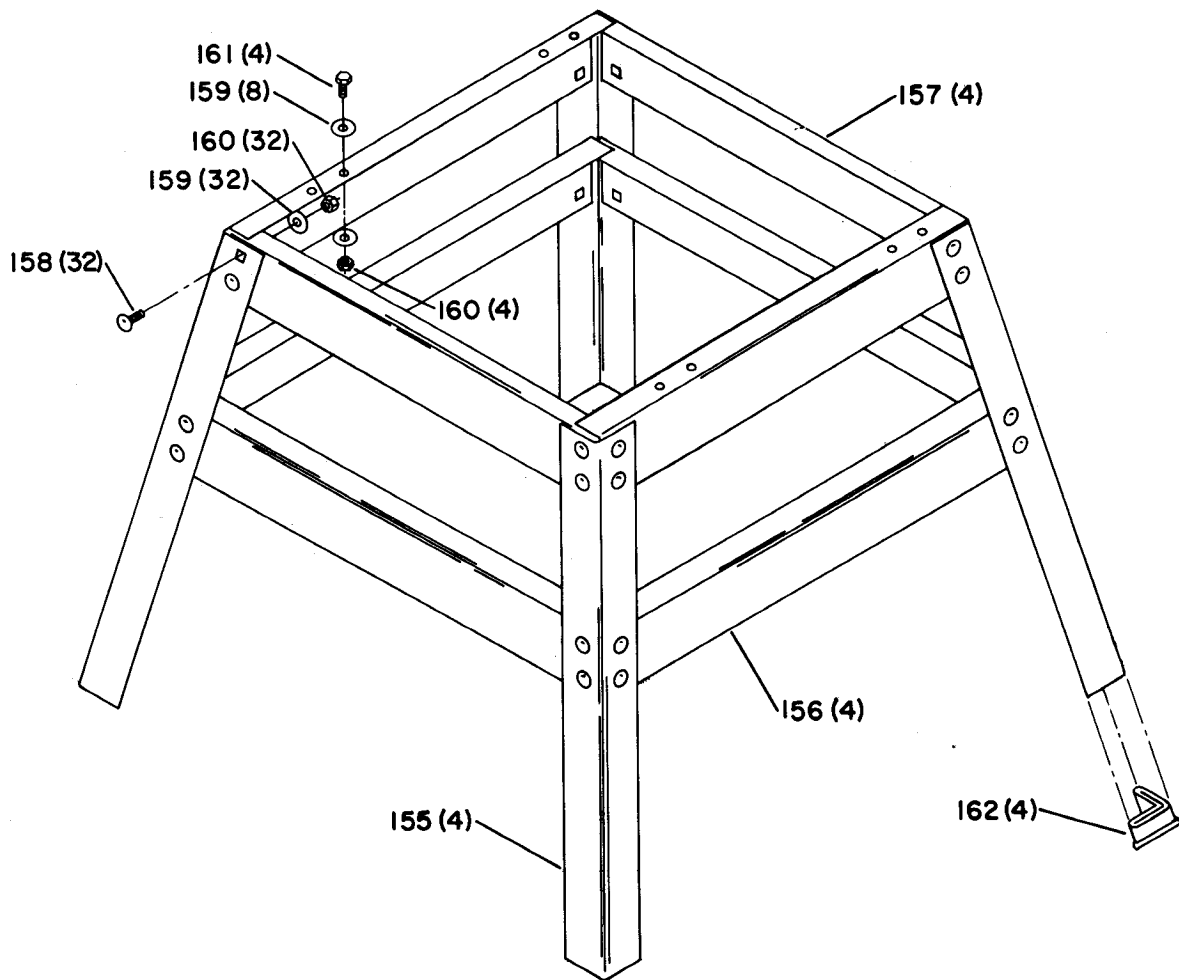

REPLACEMENT PARTS

Ref. No.	Part No.	Description
155	427-99-066-0033	Leg
156	427-99-014-0015	Bracket
157	427-99-014-0031	Bracket
158	901-11-020-0834	5/16 - 18 X 3/4" Carriage Bolt
159	904-01-010-1620	11/32 X 11/16 X 1/16" Washer
160	902-01-010-1300	5/16 - 18 Hex Lock Nut
161	901-01-060-0606	5/16 - 18 X 5/8" Hex. Hd. Screw
162	427-99-048-0001	Foot

WIRING DIAGRAM

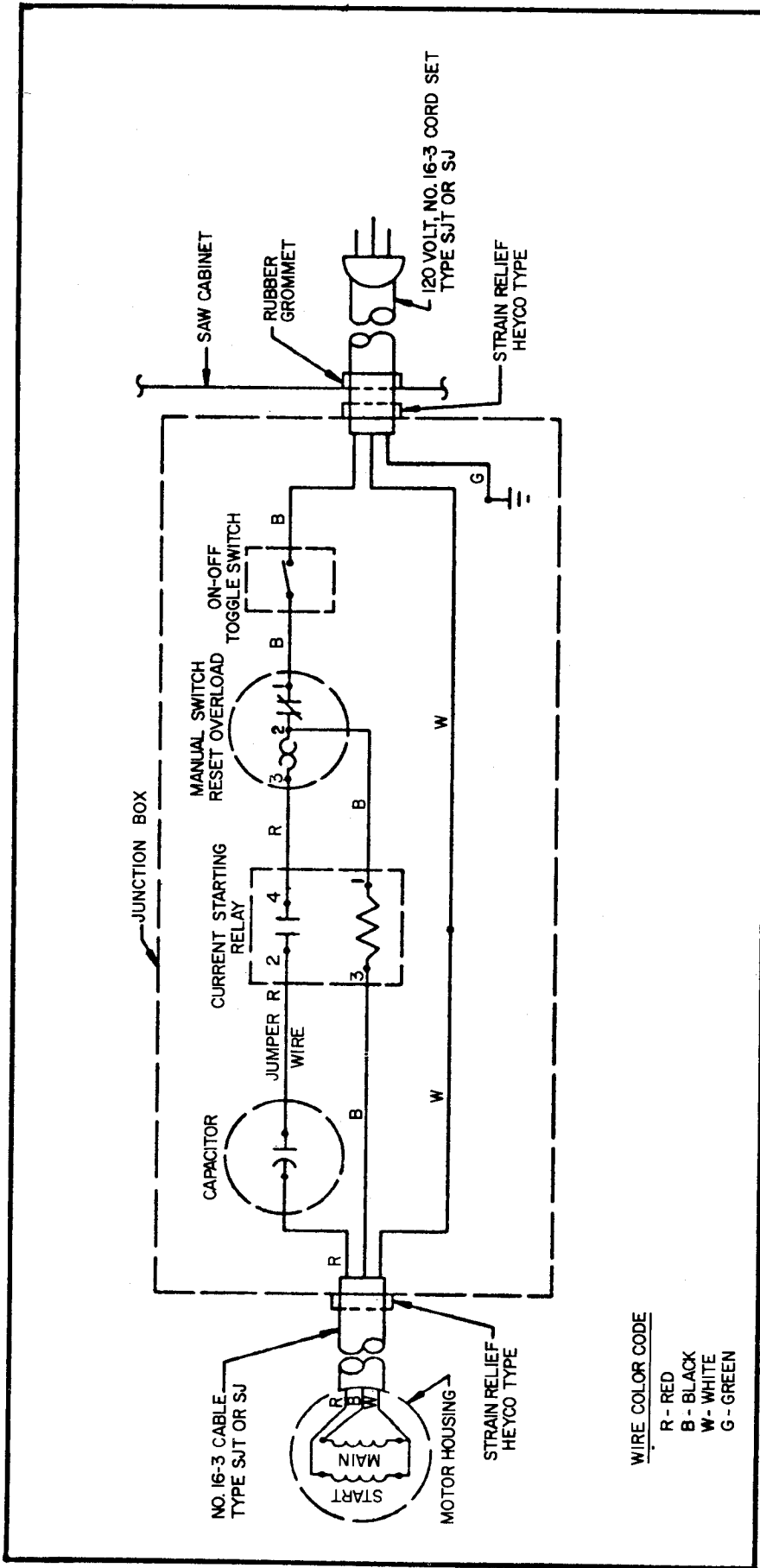

WIRE COLOR CODE
 R - RED
 B - BLACK
 W - WHITE
 G - GREEN