

STEP 1. MAKING A SAMPLE DOOR

- A) This sample door size is 12" wide by 20" long.
- B) The door thickness should be 3/4" - 7/8"

STEP 2. DETERMINING THE SIZES OF EACH PART OF THE DOOR

- A) Always use a 1/2" overlay on all sides of the door.
- B) If the door opening is 11" wide by 19" high then the door size is 12" x 20".

IMPORTANT: Use 2-7/16" wide stiles so the templates will work properly.

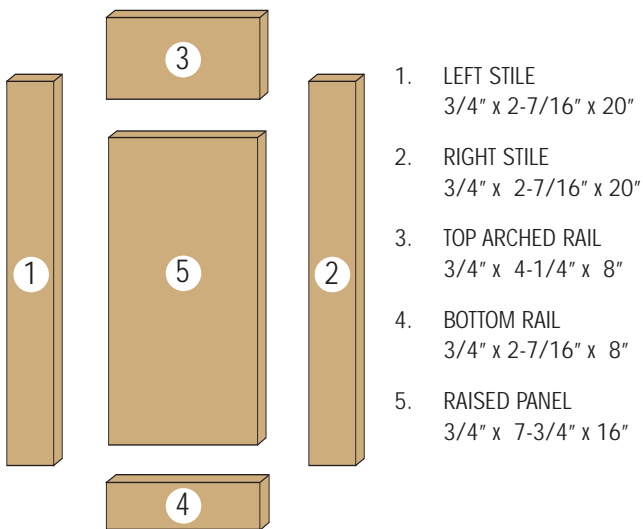

1-2. LEFT AND RIGHT STILES

- A) Always cut stiles 2-7/16" wide.
- B) Length of stiles is same as door length.

3. TOP ARCHED RAIL

- A) Cut 4-1/4" wide. Templates are 4" wide.
- B) Length of rail is found by subtracting 4" from the total door width. (Overall door width is 12" minus 4" = 8" length of rail)

NOTE: This following procedure can only be used when using 2-7/16" wide stiles. Subtract 4" from the total door width instead of 4-7/8" since 7/16" in each stile will be taken up in the pattern cut.

4. BOTTOM RAIL

- A) Always cut 2-7/16" wide.
- B) Length of rail is again found by subtracting 4" from the total door width. (Overall door width is 12" minus 4" = 8" for bottom rail lengths)

5. RAISED PANEL

- A) Width is always 1/4" less than rail length. (1/8" space should be left on each side for expansion of panel)
- B) Rail length is 8" minus 1/4" = 7-3/4" width of raised panel.
- C) Length of raised panel is found by taking the overall door length and again subtracting 4". (Overall door length is 20" minus 4" = 16" length of panel)

SUBTRACT 4" FROM THE OVERALL LENGTH OF THE DOOR. SUBTRACT 4" INSTEAD OF 4-7/8" SINCE THE PATTERN CUT TAKES UP 7/16" ON EACH RAIL.

At this time all 5 pieces of the door should be cut to the correct size.

STEP 3. CUTTING THE COPE CUTS ON EACH END OF THE 2 RAILS

- A) Cope cutter is the cutter with the bearing in the middle
- B) Set the cope cutter to the correct height in the router.
 - 1) The correct height is when, after the cut is made, the reveal on the front side should be 1/8" minimum (Illustration 1)
 - 2) Spaces A and B shown should be equal. If one is to be bigger, make B thicker for strength of panel.
- C) Set fence even with bearing.
- D) Use wooden pushblock to prevent tearout at end of cope cut.
- E) Run stock through with good side down at 14,000-16,000 RPMs.

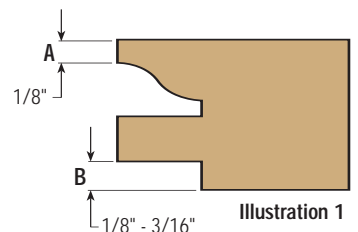

STEP 4. USING RAIL TEMPLATE TO FLUSH TRIM TOP RAIL TO CORRECT SHAPE

- A) Locate center of top rail with pencil on the back side.
- B) Pick out the correct template.

NOTE: THE SIZE ON THE TEMPLATE IS FOR THE OVERALL DOOR WIDTH. FOR THE TEMPLATES TO WORK PROPERLY STILES MUST BE MADE 2-7/16" WIDE. IF STILES ARE MADE IN DIFFERENT WIDTHS, ADJUSTMENTS IN PICKING OUT TEMPLATES MUST BE MADE.

- C) Line up template on back side of rail centering the notch of template with center line of rail. Now nail through the template into the 2 copes that were just cut (Illustration 2).

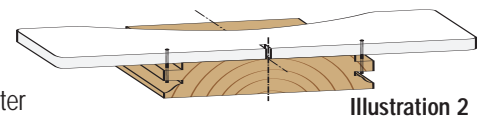

- D) Rough cut with jig or band saw within 1/8" or 1/4" of template (Illustration 3).

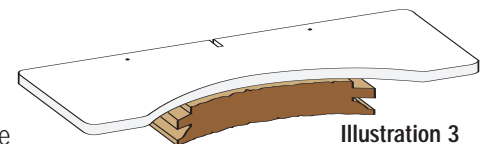

- E) Put flush trimming bit into router and set so bearing is flush with template (Illustration 4).

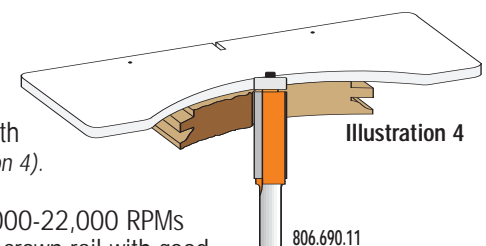

- F) Run router at 20,000-22,000 RPMs and flush trim top crown rail with good side down.

NOTE: WHEN STARTING CUT, ALWAYS REMEMBER TO MAKE CONTACT WITH BEARING TO A PLACE ON THE TEMPLATE WHERE THERE IS NO WOOD TO PREVENT KICKBACK.

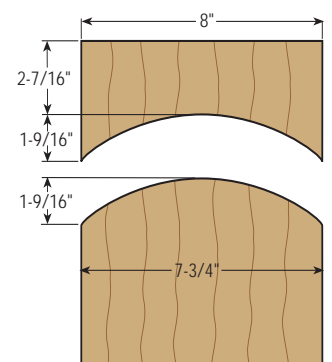

- G) Slow down at end of cut to prevent tearout. Leave template attached to rail for now.

STEP 5. USING PANEL TEMPLATE TO FLUSH TRIM THE RAISED PANEL TO SHAPE

- Locate center of raised panel on front side.
- Pick out correct template (same size as rail template).
- Line up center notch of template with center line of panel and make sure it is also square (*Illustration 5*).
- Nail template to panel about 1/2" in from each side (*Illustration 5*).

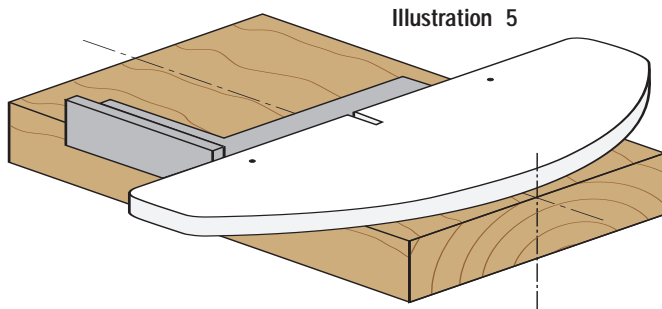

NOTE: DRIVE NAILS IN ABOUT 1/4" - 3/8". THE NAIL HOLES WILL BE MACHINED OUT WHEN RAISED PANEL CUT IS MADE.

- Rough cut stock to within 1/8" - 1/4" of template.
- Flush trim raised panel in the same manner as you did the top rail with the template on top (*Back to illustration 4*).

NOTE: AGAIN MAKE SURE BEARING COMES IN CONTACT WITH TEMPLATE FIRST AND THEN GUIDE INTO THE WOOD.

- Pull nails out after flush trimmed.

STEP 6. CUTTING FREEHAND PATTERN CUT ON TOP ARCHED RAIL

- Pattern cutter is the cutter with the bearing on top.
- Insert pattern cutting bit to correct height to match cope cut. This can be done by making a few practice cuts in scrap wood.
- Run router at 14,000-16,000 RPMs.
- Start cut with bearing making contact with template only and ease into cut. No fence is used. (*Illustration 6*).
- Slow down at end of cut to prevent any chipout.
- Remove template from top arched rail.

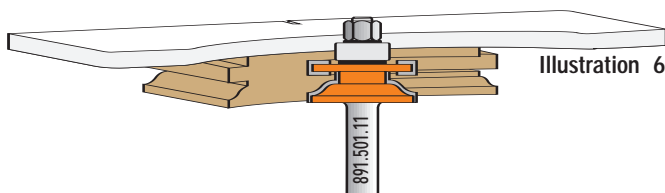

STEP 7. CUTTING THE STRAIGHT BOTTOM RAIL AND 2 STILES

- Insert fence and line up fence with bearing on the same pattern cutter.
- Run router 14,000-16,000 RPMs
- Use push-block and push bottom rail through with good side down.

STEP 8. MAKING RAISED PANEL CUT

- Insert panel cutter to correct height.
- NOTE:** IT MAY TAKE A COUPLE OF PRACTICE CUTS IN SCRAP WOOD BEFORE GETTING THE PANEL FLUSH WITH PATTERN CUT.
- Set fence so it is even with bearing on panel cutter.
 - Run router slow 10,000 RPMs. ALWAYS USE PUSH BLOCKS FOR SAFETY.
 - Make first cut across the grain with good side face down.
 - Cut with the grain on left side.
 - Remove fence and use a half-fence. (*Illustration 7*)
 - Start by re-doing left side and come around and cut the curved top of the panel freehand.
 - Install full fence and complete right side.

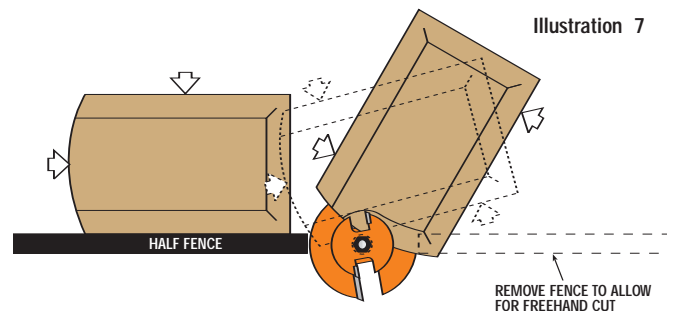

C.M.T. UTENSILI S.p.A.
Via della Meccanica
61020 Chiusa di Ginestreto
Pesaro - Italia

Phone #39 0721 48571
Fax #39 0721 481021

info@cmtutensili.com www.cmtutensili.com

CMT USA, Inc.
7609 Bentley Road Suite D
Greensboro, NC 27409 USA

phone 336.854.0201 toll-free 1.888.268.2487
fax 336.854.0903 free-fax 1.800.268.9778

info@cmtusa.com www.cmtusa.com